



New
collection

aQuasanit®
BY IDRO
3 Bile

aQuasanit[®]
BY **IDRO**[®]
Bric

Evolution / Concept / 4

Innovation solutions

Accessori da muro / 12

Wall mounted accessories

Complementi / 44

Bathroom accessories

Accessori da appoggio / 66

Free standing accessories

Box doccia New plus / 112

New plus shower enclosures

Aquasanit Collection
2022 IDRO-BRIC® S.p.A. (09.2022)

IDRO-BRIC S.p.A.
Via dell'Industria, 4/b - 24040 Casirate d'Adda (BG) - Italy
Tel. +39 0363.326690 - Fax +39 0363.326710
info@idrobric.it - www.idrobric.it

Le misure sono da considerarsi indicative. Idro-Bric S.p.A. si riserva il diritto di apportare, in qualsiasi momento, modifiche tecniche, costruttive e dimensionali utili al miglioramento della nostra produzione

EVOLUTION

Eleganza in stile minimal

Elegance in minimalist style

Eleganz im minimalistischen stil

Élégance dans un style minimaliste

Elegancia en estilo minimalista

Evolution: il nome racchiude pienamente l'essenza di eleganza fuori dagli schemi. La finitura nera sottolinea al meglio il carattere della serie: impetuoso e lineare, elegante e semplice allo stesso tempo.

Evolution: the name includes the essence of elegance outside the box. The black finish emphasizes the character of the series: impetuous and linear, elegant and simple at the same time.

Evolution: Der Name verkörpert die Essenz einer unkonventionellen Eleganz. Das Ausführung schwarz wird der Charakter der Serie am besten hervorgehoben: ungestüm und geradlinig, elegant und schlicht zugleich.

Evolution: le nom inclut l'essence de l'élégance hors des sentiers battus. La finition noire souligne le caractère de la série: impétueux et linéaire, élégant et simple à la fois.

Evolución: el nombre incluye la esencia de la elegancia fuera de la caja. L'acabado negro destaca el carácter de la serie: impetuoso y lineal, elegante y simple al mismo tiempo.



BATHROOM
**MAGIC / SP...
KEEP CLEAN**

BATHING A FRAGRANCE AND MAKE IT A...

**THE DAY BE...
WITH BEAU...**

we only live once
CAPACITY: 250ml

BATHROOM

Life requires a sense of...
**SHOWER GEL / SHAMP...
HOT BATH**

BATHING A FRAGRANCE AND MAKE IT A...

Do not choose comfort at the age of hardship, when you have
or did. Just remember make yourself no grumpy.

Life is short, in a limited time, do what we like, every day have
young positive attitude. If you have something you like, do it, and
remember too much, as long as it is worth it, why don't you try?

People live without knowing what to do or what they want.
The more simple, the more life, the pursuit of a better life.

Love is not about how beautiful it is, it's about how...

CAPACITY: 500ml

EVOLUTION

Serie realizzata in alluminio, finitura nero opaco, corredi in vetro satinato, fissaggio con speciale biadesivo 3M opzionale fissaggio ad incollo (colla venduta separatamente)

Series made of aluminium, satin black finish, satin glas complements fixing with double-sided 3M adhesive tape, optional glue fixing (glue not included)

Serie aus aluminium, ausführung schwarz matt, Zubehörteile aus satiniertem glas montage mit 3M-doppelklebeband, optional zum kleben (Kleber separat erhältlich)

Série en aluminium, finition noire mat, pièces en verre satiné montage avec adhésif spécial 3M, optionelle montage avec colle (colle vendue séparément)

Serie en aluminio, acabado negro mate, accesorios en vidrio satinado montaje con adhesivos 3M, opcional montaje con cola (cola vendida separatamente)

10
YEARS-GARANZIA
GUARANTEE



3M





A205090NE
cm L30 x H25 x P10,8



A205490NE
L30 x H25 x P12 cm



A20590ANE
L25 x H3 x P6 cm



A20590BNE
L40 x H3 x P6 cm



A20521SNE
L3 x H8,8 x P2,1 cm



A205255NE
L20 x H6,5 x P10,3 cm



A205140NE
L16,3 x H39 x P12,6 cm

CONCEPT

Straordinariamente pratici

Exceptionally practical

Aussergewöhnlich praktisch

Praticité extraordinaire

Extraordinariamente prácticos

Concept è un nuovo concetto di arredo bagno. Grazie alle funzioni intelligenti, gli accessori diventano un vero complemento d'arredo per un bagno caratterizzato da stile e funzionalità.

Concept is a new conception for accessorizing the bathroom. The intelligent functionality of the accessories is an additional complement for a stylish and practical bathroom.

Concept ist ein neues Konzept für die Ausstattung des Badezimmers. Die intelligente Funktionalität des Zubehörs ist eine zusätzliche Ergänzung für ein stilvolles und praktisches Badezimmer.

Concept est un nouveau concept pour la salle de bain. La fonctionnalité des accessoires est un avantage supplémentaire pour une salle de bain caractérisée par raffinement et efficience.

Concept es un nuevo concepto por la decoración del baño. La funcionalidad de los accesorios es un beneficio adicional por un baño caracterizado por elegancia y eficiencia.

NEW-AGE[®]
ANTI-WRINKLE +
FIRMING
ANTI-RIDES +
FERMETÉ
COMFORTING
FOAMING CLEANSER
NETTOYANT MOUSSANT
ULTRA-COMFORT
HYPO-ALLERGENIC
HYPO-ALLERGÈNE



CONCEPT

Serie realizzata in acciaio SS304, Abs e ottone, finitura bianca, fissaggio con viti e tasselli inclusi, opzionale fissaggio ad incollo (supporti per fissaggio incollo venduti separatamente art. A112008PI)

Serie made of SS304 stainless steel, abs and brass, white finish Fixing set included (screws and plugs), optional plug-less mounting (wall plates adapters for mounting with adhesive sold separately A112008PI)

Serie aus SS304-edelstahl, abs und messing, und weissem abs, ausführung Weiß Befestigungsset Inbegriffen (Schrauben und Dübel), wahlweise zum kleben geeignet (wandplatten als klebeadapter separat zu kaufen, art.Nr. A112008PI)

Série en acier SS304, abs et laiton, finition blanc Kit de fixation inclus (vis et chevilles), optional fixation avec colle (plaques pour la fixation vendu séparément art. A112008PI)

Serie en acero SS304, abs y latón, acabado blanco Fijación con tornillos incluidos, opcional montaje con cola (no incluye los soportes para el montaje con la cola, vendidos por separado art. A112008PI)





A112001MR

L29 x H5,3 x P12 cm



A112002MA

L22 x H5,3 x P22 cm



A112009MT

L32,5 x H4,6 x P11 cm



A112003MM

L37 x H7,9 x P12,2 cm



A112007SP

L25 x H4 x P11,8 cm



A112006GA

L27 x H7,2 x P1,7 cm



A112004AS

L33,8 x H50 x P11,5 cm



A112005PR

L17,5 x H8,7 x P11 cm

ripiano in vetro
glass shelf
glasablage
tablette verre
estante vidrio



A112008PI

2 pcs - Ø 3,6 cm





Accessori da muro

Wall mounted
accessories

Blend

3
YEARS-GARANZIA
GUARANTEE



Serie realizzata in alluminio, abs e acciaio, finitura bianca/nera, complementi in vetro satinato, fissaggio con viti e tasselli inclusi

Series made of aluminum, abs and steel, white /black finish, satin glass complements. Fixing set included (screws and plugs)

Serie aus Aluminium, ABS und Stahl, Ausführung schwarz und weiß, Zubehörteile aus satiniertem Glas Befestigungsset (Schrauben und Dübel) im Lieferumfang Enthalten

Série en aluminium, abs et acier, finition blanche et noire, avec pièces en verre satiné Fixation avec vis et chevilles, inclus

Serie en aluminio, abs y acero, acabado blanco y negro, accesorios en vidrio satinado Fijación con tornillos (incluidos)

NE

Nero
Black
Noire
Schwarz
Negro

WW

Bianco
White
Blanc
Weiß
Blanco





A212100NE
A212100WW

cm L. 6,7 x H. 10,9 x P. 9,5



A212110NE
A212110WW

cm L. 10,8 x H. 7,2 x P. 11,5



A212210NE
A212210WW

cm L. 8,4 x H. 10,8 x P. 7,5



A21290CNE
A21290CWW

cm L. 60 x H. 10,8 x P. 7,5

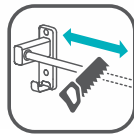

accorciabile
shortenable
raccourci
kürzbar
acortable



A212090NE
A212090WW

cm L. 21 x H. 4,5 x P. 21



A212160NE
A212160WW

cm L. 18,9 x H. 23,3 x P. 7,5



A212240NE
A212240WW

cm L. 30 x H. 5 x P. 4,5



A212140NE
A212140WW

cm L. 7,5 x H. 38 x P. 7,5



A212250NE
A212250WW

cm L. 16 x H. 4,6 x P. 11



Packaging in cartone
completamente riciclabile

Packaging made of fully
recyclable cardboard.

Packaging aus vollständig
recyclbarem Karton.

Emballage en carton
entièrement recyclable

Embalaje en cartón
totalmente reciclable

Skyline

Serie realizzata in acciaio 304, finitura nera o acciaio spazzolato, corredi in vetro satinato, fissaggio con biadesivo 3m, opzionale fissaggio ad incollo (colla venduta separatamente)

Serie made of ss304 stainless steel, black/ brushed steel finish, fixing with double-sided 3m adhesive tape, optional glue fixing (glue not included)

Serie aus ss304-edelstahl, ausführung schwarz/stahl gebürstet, zubehörteile aus satiniertem glas montage mit 3m-doppelklebeband, optional zum kleben (kleber separat erhältlich)

Série en acier ss304, finition noire/ brossée, pièces en verre satiné montage avec adhésif spécial 3m, optionelle montage avec colle (colle vendue séparément)

Serie en acero ss304, acabado negro/ cepillado, accesorios en vidrio satinado montaje con adhesivos 3m, opcional montaje con cola (cola vendida separadamente)



NE

Nero
Black
Noire
Schwarz
Negro

AS

Acciaio spazzolato
Brushed steel
Acier brossé
Sthl
Acero





A202100AS
A202100NE
cm L. 10,5 x H. 10,5 x P 11,5



A202110AS
A202110NE
cm L. 13,2 x H. 5,5 x P. 11



A20221SAS
cm L. 3 x H. 5 x P. 3



A20290AAS
A20290ANE
cm L. 30 x H. 5,7 x P 8,2

A20290BAS
A20290BNE
cm L. 45 x H. 5,7 x P. 8,2
A20290CAS
A20290CNE
cm L. 60 x H. 5,7 x P. 8,2



A202160AS
A202160NE
cm L. 22 x H. 10 x P. 6,5



A202210AS
A202210NE
cm L. 10 x H. 5 x P. 3



A202250AS
A202250NE
cm L. 16 x H. 5,5 x P. 8



A202140AS
A202140NE
cm L. 10,5 x H. 35 x P. 11



A00006G
cm L. 6 x H. 13,5 x P. 3,5



Packaging in cartone
completamente riciclabile
Packaging made of fully
recyclable cardboard.
Packaging aus vollständig
recyclbarem Karton.
Emballage en carton
entièrement recyclable
Embalaje en cartón
totalmente reciclable

Frame

Serie realizzata in zama e acciaio, finitura cromo, corredi in vetro satinato fissaggio con viti e tasselli inclusi, opzionale fissaggio ad incollo, (colla venduta separatamente)

Series made of zamak and steel, chrome finish, satin glass complements fixing set included (screws and plugs), optional glue fixing (glue sold separately)

Serie aus zamak und edelstahl, chromausführung, die zubehörteile aus satiniertem glas befestigungsset enthalten (schrauben und dübel), optional montage zum kleben (kleber separat erhältlich)

Série en zamak et acier, finition chromée, pièces en verre satiné kit de fixation inclus (vis et chevilles), optionnel fixation avec colle, colle vendue séparément

Serie en zamak y acero, acabado cromado, complementos de vidrio satinado fijación con tornillos incluidos, opcional fijación con pegamento (vendido separadamente)

10
YEARS-GARANZIA
GUARANTEE





A208100CR
cm L. 6,4 x H. 11,1 x P. 10



A208110CR
cm L. 10,5 x H. 5,5 x P. 12



A20821SCR
cm L. 5 x H. 5 x P. 7,2



A208150CR
cm L. 40,3 x H. 5 x P. 5,5



A20890ACR
cm L. 30 x H. 5 x P. 8,5
A20890BCR
cm L. 45 x H. 5 x P. 8,5



A208160CR
cm L. 14,8 x H. 19,1 x P. 7,2



A208250CR
cm L. 16,7 x H. 5 x P. 8,5



A208140CR
cm L. 8 x H. 45,5 x P. 8



A00006G
cm L. 6 x H. 13,5 x P. 3,5



Packaging in cartone
completamente riciclabile
Packaging made of fully
recyclable cardboard.
Packaging aus vollständig
recyclbarem Karton.
Emballage en carton
entièrement recyclable
Embalaje en cartón
totalmente reciclable

Shell

10
YEARS-GARANZIA
GUARANTEE



Serie realizzata in zama e acciaio, finitura cromo, corredi in vetro satinato fissaggio con viti e tasselli inclusi, opzionale fissaggio ad incollo, colla venduta separatamente

Series made of zamak and steel, chrome finish, satin glass complements fixing set included (screws and plugs), optional glue fixing (glue sold separately)

Serie aus zamak und edelstahl, chromausführung, die zubehörteile aus satiniertem glas befestigungsset enthalten (schrauben und dübel), optional montage zum kleben (kleber separat erhältlich)

Série en zamak et acier, finition chromée, pièces en verre satiné kit de fixation inclus (vis et chevilles), optionnel fixation avec colle, colle vendue séparément

Serie en zamak y acero, acabado cromado, complementos de vidrio satinado fijación con tornillos incluidos, opcional fijación con pegamento (vendido separadamente)

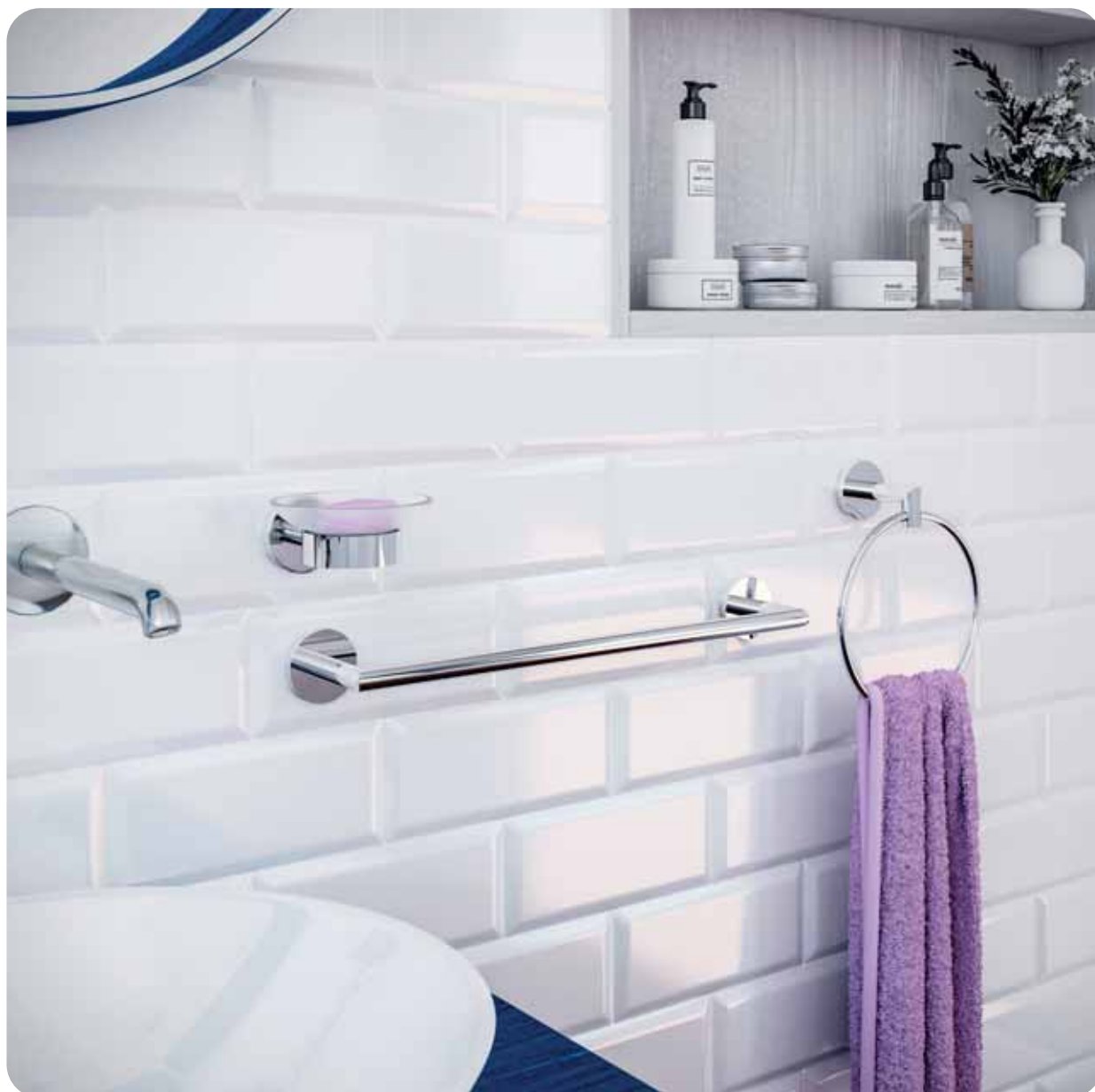



A209100CR
cm L. 6,8 x H. 9,5 x P. 11,3



A209110CR
cm L. 10,7 x H. 5,2 x P. 13,2



A209210CR
cm L. 7 x H. 5,2 x P. 5,2



A209150CR
cm L. 37,6 x H. 5,6 x P. 5,9



A20990ACR
cm L. 30 x H. 5,2 x P. 7,3

A20990BCR
cm L. 45 x H. 5,2 x P. 7,3



A209160CR
cm L. 17,5 x H. 21,4 x P. 7,3



A209250CR
cm L. 17,3 x H. 5,2 x P. 7,3



A209140CR
cm L. 8 x H. 44,5 x P. 8



A00006G
cm L. 6 x H. 13,5 x P. 3,5



Packaging in cartone
completamente riciclabile
Packaging made of fully
recyclable cardboard.
Packaging aus vollständig
recyclbarem Karton.
Emballage en carton
entièrement recyclable
Embalaje en cartón
totalmente reciclable

Steel

Serie realizzata in acciaio 304, finitura acciaio spazzolato, corredi in vetro satinato, fissaggio con viti e tasselli inclusi, opzionale fissaggio ad incollo, colla venduta separatamente

Series made of steel 304, chrome brushed steel, satin glass complements fixing set included (screws and plugs), optional glue fixing (glue sold separately)

Serie aus 304-edelstahl, ausführung stahl gebürstet, die zubehörteile aus satiniertem glas befestigungsset enthalten (schrauben und dübel), optional montage zum kleben (kleber separat erhältlich)

Série en acier 304, finition brossée, pièces en verre satiné kit de fixation inclus (vis et chevilles), optionnel fixation avec colle, colle vendue séparément

Serie en acero 304, acabado cepillado, complementos de vidrio satinado fijación con tornillos incluidos, opcional fijación con pegamento (vendido separadamente)

10
YEARS-GARANZIA
GUARANTEE

MADE WITH
304
STAINLESS
STEEL





A207100AS
cm L. 12,6 x H. 9,5 x P. 8,1



A207110AS
cm L. 15,8 x H. 5,7 x P. 8,9



A207210AS
cm L. 6,5 x H. 5,8 x P. 6



A207150AS
cm L. 36,5 x H. 5,7 x P. 6



A20790AAS
cm L. 30 x H. 5,8 x P. 7,7

A20790BAS
cm L. 45 x H. 5,8 x P. 7,7



A207160AS
cm L. 16 x H. 18,5 x P. 6



A207250AS
cm L. 19,5 x H. 8 x P. 6



A207140AS
cm L. 8 x H. 45,5 x P. 8



A00006G
cm L. 6 x H. 13,5 x P. 3,5



Packaging in cartone
completamente riciclabile
Packaging made of fully
recyclable cardboard.
Packaging aus vollständig
recyclbarem Karton.
Emballage en carton
entièrement recyclable
Embalaje en cartón
totalmente reciclable

Queen

Serie realizzata in zama e acciaio, finitura cromo, corredi in vetro satinato, fissaggio con viti e tasselli inclusi

Series made of zamak and steel, chrome finish, satin glass complements, fixing set included (screws and plugs)

Serie aus zamak und edelstahl, chromausführung, die zubehörteile aus satiniertem glas befestigungsset enthalten (schrauben und dübel)

Série en zamak et acier, finition chromée, pièces en verre satiné kit de fixation inclus (vis et chevilles)

Serie en zamak y acero, acabado cromado, complementos de vidrio satinado fijación con tornillos incluidos

10
YEARS-GARANZIA
GUARANTEE





A210100CR
cm L. 12,6 x H. 9,5 x P. 8,1



A210110CR
cm L. 15,8 x H. 5,7 x P. 8,9



A210210CR
cm L. 6,5 x H. 5,8 x P. 6



A210150CR
cm L. 36,5 x H. 5,7 x P. 6



A21090ACR
cm L. 30 x H. 5,8 x P. 7,7
A21090BCR
cm L. 45 x H. 5,8 x P. 7,7



A210160CR
cm L. 16 x H. 18,5 x P. 6



A210250CR
cm L. 19,5 x H. 8 x P. 6



A210140CR
cm L. 8 x H. 44,5 x P. 8



Packaging in cartone
completamente riciclabile
Packaging made of fully
recyclable cardboard.
Packaging aus vollständig
recyclbarem Karton.
Emballage en carton
entièrement recyclable
Embalaje en cartón
totalmente reciclable

Link

Serie realizzata in zama e acciaio, finitura cromo, corredi in vetro satinato
Fissaggio con viti e tasselli inclusi, opzionale fissaggio ad incollo, colla venduta separatamente

Series made of zamak and steel, chrome finish, satin glass complements
Fixing set included (screws and plugs), optional glue fixing (glue sold separately)

Serie aus Zamak und Edelstahl, Chromausführung, Die Zubehörteile aus satiniertem Glas Befestigungsset Enthalten (Schrauben und Dübel), optional montage zum kleben (Kleber separat erhältlich)

Série en zamak et acier, finition chromée, pièces en verre satiné Kit de fixation inclus (vis et chevilles), optionnel fixation avec colle, colle vendue séparément

Serie en zamak y acero, acabado cromado, complementos de vidrio satinado Fijación con tornillos incluidos, opcional fijación con pegamento (vendido separadamente)

10
YEARS-GARANZIA
GUARANTEE

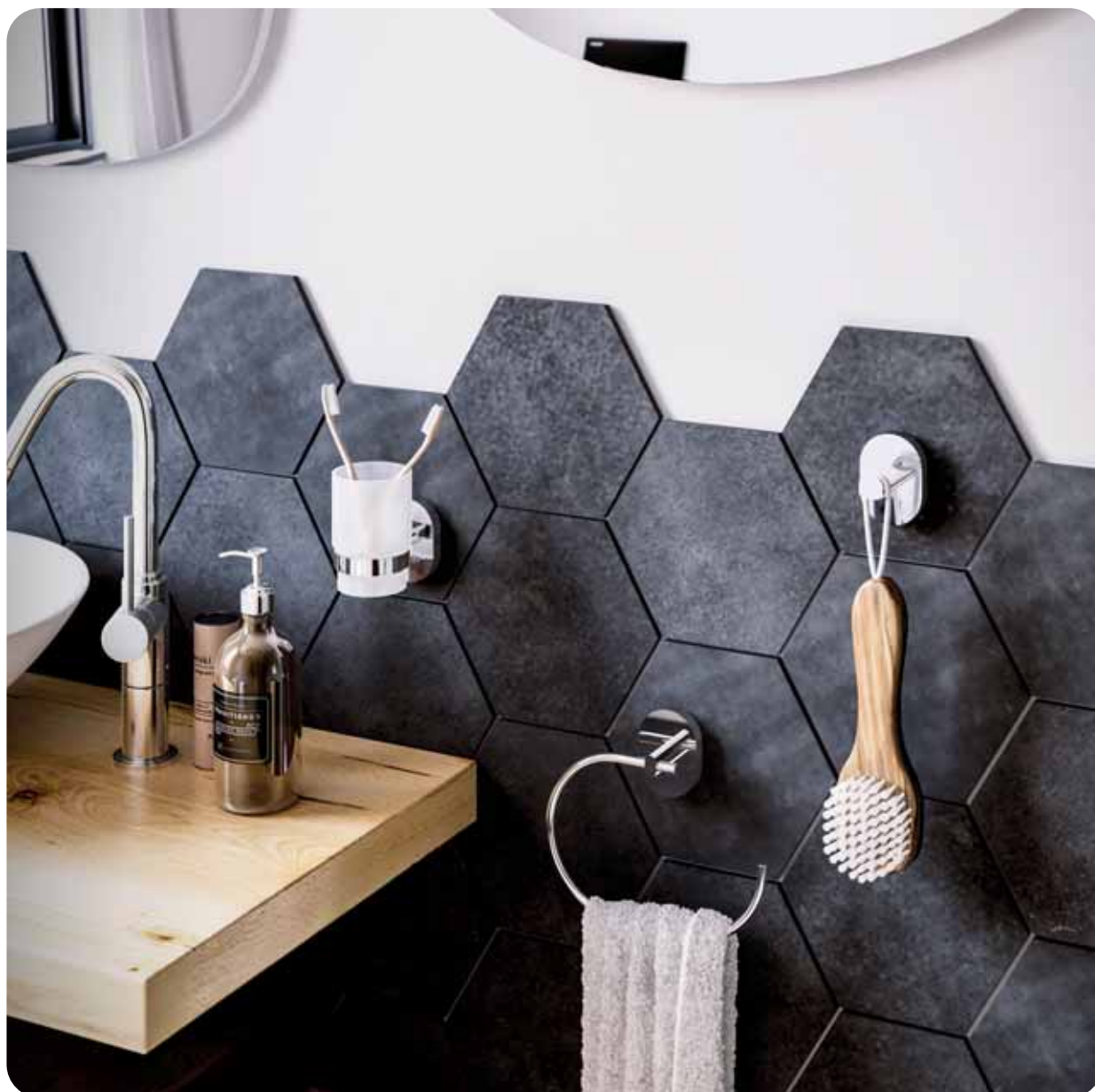



A211100CR
cm L. 6,8 x H. 10,5 x P. 10,3



A211110CR
cm L. 10,9 x H. 7,1 x P. 12,4



A21121SCR
cm L. 5 x H. 7 x P. 5,5

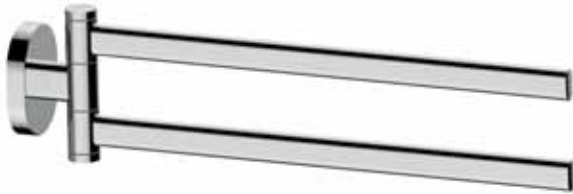

A211150CR
cm L. 37,3 x H. 7 x P. 5



A21190ACR
cm L. 30 x H. 7 x P. 7,2
A21190BCR
cm L. 45 x H. 7 x P. 7,2

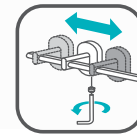

interasse regolabile
adjustable
einstellbar
réglable
ajustable



A211160CR
cm L.20 x H. 17,2 x P. 4,2

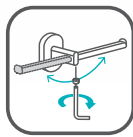

Reversibile
Reversible
Réversible
Reversibel
Reversibile

A211250CR
cm L. 17 x H. 7 x P. 7,2



A211140CR
cm L. 11,5 x H. 37,5 x P. 13,6



A00006G
cm L. 6 x H. 13,5 x P. 3,5



Packaging in cartone
completamente riciclabile
Packaging made of fully
recyclable cardboard.
Packaging aus vollständig
recyclbarem Karton.
Emballage en carton
entièrement recyclable
Embalaje en cartón
totalmente reciclable

Leaf

10
YEARS-GARANZIA
GUARANTEE

Serie realizzata in alluminio, finitura lucida, complementi in ceramica bianca
Fissaggio con viti e tasselli inclusi

Series made of aluminium, shiny finish, complements made of white ceramic
Fixing set included (screws and plugs)

Serie aus Aluminium, Ausführung glänzend, Zubehörteile aus weißer Keramik
Befestigungsset (Schrauben und Dübel) im Lieferumfang enthalten

Série en aluminium, finition brillante, pièces en céramique blanche
Fixation avec vis et chevilles inclus

Serie en aluminio, acabado brillante, complementos de cerámica blanca
Fijación con tornillos incluidos





A206100AS
cm L. 7 x H. 10 x P. 10,3



A206110AS
cm L. 12,5 x H. 4,6 x P. 10,2



A206210AS
cm L. 10,6 x H. 4,2 x P. 3,7

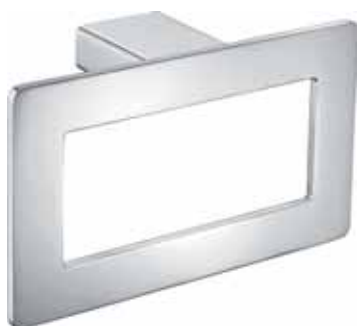

A206160AS
cm L. 22 x H. 12 x P. 6,8



A206250AS
cm L. 17,3 x H. 3,6 x P. 6,8



A20690AAS
cm L. 30 x H. 2,6 x P. 6,8

A20690BAS
cm L. 45 x H. 2,6 x P. 6,8



A206140AS
cm L. 7 x H. 38,5 x P. 10,3



Packaging in cartone
completamente riciclabile
Packaging made of fully
recyclable cardboard.

Packaging aus vollständig
recyclbarem Karton.

Emballage en carton
entièrement recyclable

Embalaje en cartón
totalmente reciclable

Nexo

Serie realizzata in zamak e acciaio, finitura cromo, corredi in vetro trasparente
La placca X consente 3 tipologie di fissaggio: riutilizzare i vecchi fori, praticare nuovi fori, incollo (colla inclusa)

Series made of zamak and steel, chrome finish, transparent glass complements.
The X wall-plate allows 3 mounting options: mounting using old drilled holes, mounting with new holes, with glue (included)

Serie aus Zamak und Edelstahl, Chromausführung, Zubehörteilen aus transparentem Glas. Die X-Befestigungsplatte ermöglicht: Befestigung Verwendung alter Bohrlöcher, mit neuen Bohrlöchern, durch Kleben (Kleber im Lieferumfang enthalten)

Série en zamak et acier, finition chromée, pièces en verre transparent
La plaque X permet 3 types de fixation: réutiliser vieux trous, percer nouveaux trous, collage (colle incluse)

Serie en zamak y acero, acabado cromado, complementos de vidrio transparente
La placa X permite 3 tipos de fijación: reutilizar agujeros viejos, taladrar otros nuevos, pegar (pegamento incluido)



3 Possibilità di fissaggio / 3 mounting options / drei Befestigungsoptionen
3 types de fixation / 3 tipos de fijación

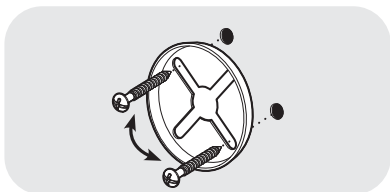

RE-FIX

riutilizza vecchi fori
using old drilled holes
verwendung alter Bohrlöcher
réutiliser vieux trous
reutilizar agujeros viejos

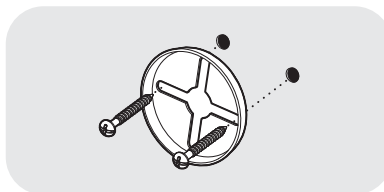

SCREW-FIX

fissaggio con nuovi fori
mounting with new holes
mit neuen Bohrlöchern
percer nouveaux trous
taladrar nuevos agujeros

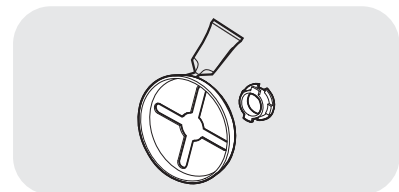

GLUE-FIX

fissaggio con colla
glue fixing
durch Kleben
avec colle
con pegamento



A203100CR
cm L. 6,8 x H. 9,9 x P. 10,7



A203110CR
cm L. 10,8 x H. 5,4 x P. 13



A203210CR
cm L. 8 x H. 5,4 x P. 6



A203150CR
cm L. 43,6 x H. 6,4 x P. 5,4



A203160CR
cm L. 20 x H. 17 x P. 4,2



A20390ACR
cm L. 30 x H. 5,4 x P. 7,3
A20390BCR
cm L. 45 x H. 5,4 x P. 7,3

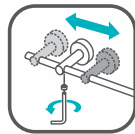

interasse regolabile
adjustable
einstellbar
réglable
ajustable



A203140CR
cm L. 11,5 x H. 38 x P. 13,2



A203250CR
cm L. 13,5 x H. 10,3 x P. 4,2



Packaging in cartone
completamente riciclabile
Packaging made of fully
recyclable cardboard.
Packaging aus vollständig
recyclbarem Karton.
Emballage en carton
entièrement recyclable
Embalaje en cartón
totalmente reciclable

Xeno

Serie realizzata in zamak e acciaio, finitura cromo, corredi in vetro trasparente
La placca X consente 3 tipologie di fissaggio: riutilizzare i vecchi fori, praticare nuovi fori, incollo (colla inclusa)

Series made of zamak and steel, chrome finish, transparent glass complements.
The X wall-plate allows 3 mounting options: mounting using old drilled holes, mounting with new holes, with glue (included)

Serie aus Zamak und Edelstahl, Chromausführung, Zubehörteilen aus transparentem Glas. Die X-Befestigungsplatte ermöglicht: Befestigung Verwendung alter Bohrlöcher, mit neuen Bohrlöchern, durch Kleben (Kleber im Lieferumfang enthalten)

Série en zamak et acier, finition chromée, pièces en verre transparent
La plaque X permet 3 types de fixation: réutiliser vieux trous, percer nouveaux trous, collage (colle incluse)

Serie en zamak y acero, acabado cromado, complementos de vidrio transparente
La placa X permite 3 tipos de fijación: reutilizar agujeros viejos, taladrar otros nuevos, pegar (pegamento incluido)



3 Possibilità di fissaggio / 3 mounting options / drei Befestigungsoptionen
3 types de fixation / 3 tipos de fijación

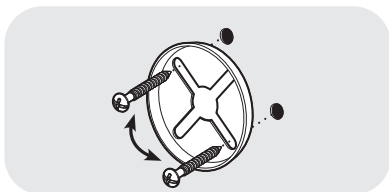

RE-FIX

riutilizza vecchi fori
using old drilled holes
verwendung alter Bohrlöcher
réutiliser vieux trous
reutilizar agujeros viejos

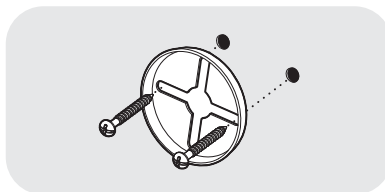

SCREW-FIX

fissaggio con nuovi fori
mounting with new holes
mit neuen Bohrlöchern
percer nouveaux trous
taladrar nuevos agujeros

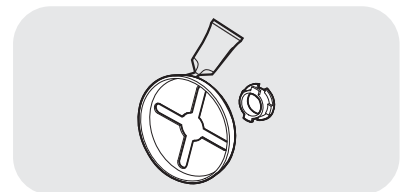

GLUE-FIX

fissaggio con colla
glue fixing
durch Kleben
avec colle
con pegamento



A204100CR
cm L. 6,8 x H. 9,9 x P. 11



A204110CR
cm L. 10,8 x H. 5,4 x P. 13



A204210CR
cm L. 5,4 x H. 5,4 x P. 4,8



A204150CR
cm L. 43,6 x H. 6,4 x P. 5,4



A204160CR
cm L. 15,3 x H. 16,8 x P. 5,8



A20490ACR
cm L. 30 x H. 5,4 x P. 7,3
A20490BCR
cm L. 45 x H. 5,4 x P. 7,3

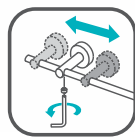

interasse regolabile
adjustable
einstellbar
réglable
ajustable



A204140CR
cm L. 8,5 x H. 40 x P. 12



A204250CR
cm L. 16,9 x H. 5,4 x P. 7,9



Packaging in cartone
completamente riciclabile
Packaging made of fully
recyclable cardboard.
Packaging aus vollständig
recyclbarem Karton.
Emballage en carton
entièrement recyclable
Embalaje en cartón
totalmente reciclable

Flat

Serie realizzata in ottone e zama, finitura cromo, complementi in vetro satinato fissaggio con viti e tasselli inclusi, opzionale fissaggio ad incollo, colla venduta separatamente

Series made of brass and zamak, chrome finish, satin glass complements fixing set included (screws and plugs), optional glue fixing (glue sold separately)

Serie aus Messing und Zamak, Chromausführung, Zubehörteile aus satiniertem Glas Befestigungsset Enthalten (Schrauben und Dübel), optional montage zum kleben (Kleber separat erhältlich)

Série en laiton et zamak, finition chromée, pièces en verre satiné kit de fixation inclus (vis et chevilles), optionnel fixation avec colle, colle vendue séparément

Serie en en latón y zamak, acabado cromado, complementos de vidrio satinado fijación con tornillos incluidos, opcional fijación con pegamento (vendido separadamente)





A107100CR21
cm L. 9 x H. 13 x P. 12



A107110CR21
cm L. 11 x H. 9 x P. 13



A107210CR
cm L. 7 x H. 9 x P. 4



A10790ACR
cm L. 30 x H. 9 x P. 6

A10790BCR
cm L. 45 x H. 9 x P. 6



A107150CR
cm L. 40 x H. 9 x P. 4



A10716TCR
cm L. 22 x H. 17 x P. 6



A107250CR
cm L. 18 x H. 9 x P. 6



A107140CR21
cm L. 11 x H. 40 x P. 14



A00006G
cm L. 6 x H. 13,5 x P. 3,5



Packaging in cartone
completamente riciclabile
Packaging made of fully
recyclable cardboard.
Packaging aus vollständig
recyclbarem Karton.
Emballage en carton
entièrement recyclable
Embalaje en cartón
totalmente reciclable

Cubo

Serie realizzata in zama e acciaio, finitura cromo, corredi in vetro satinato
fissaggio con viti e tasselli inclusi, opzionale fissaggio ad incollo, colla venduta
separatamente

Series made of zamak and steel, chrome finish, satin glass complements
fixing set included (screws and plugs), optional glue fixing (glue sold separately)

Serie aus Zamak und Edelstahl, Chromausführung, Die Zubehörteile aus satiniertem
Glas Befestigungsset Enthalten (Schrauben und Dübel), optional montage zum
kleben (Kleber separat erhältlich)

Série en zamak et acier, finition chromée, pièces en verre satiné
kit de fixation inclus (vis et chevilles), optionnel fixation avec colle, colle vendue
séparément

Serie en zamak y acero, acabado cromado, complementos de vidrio satinado
fijación con tornillos incluidos, opcional fijación con pegamento (vendido
separadamente)

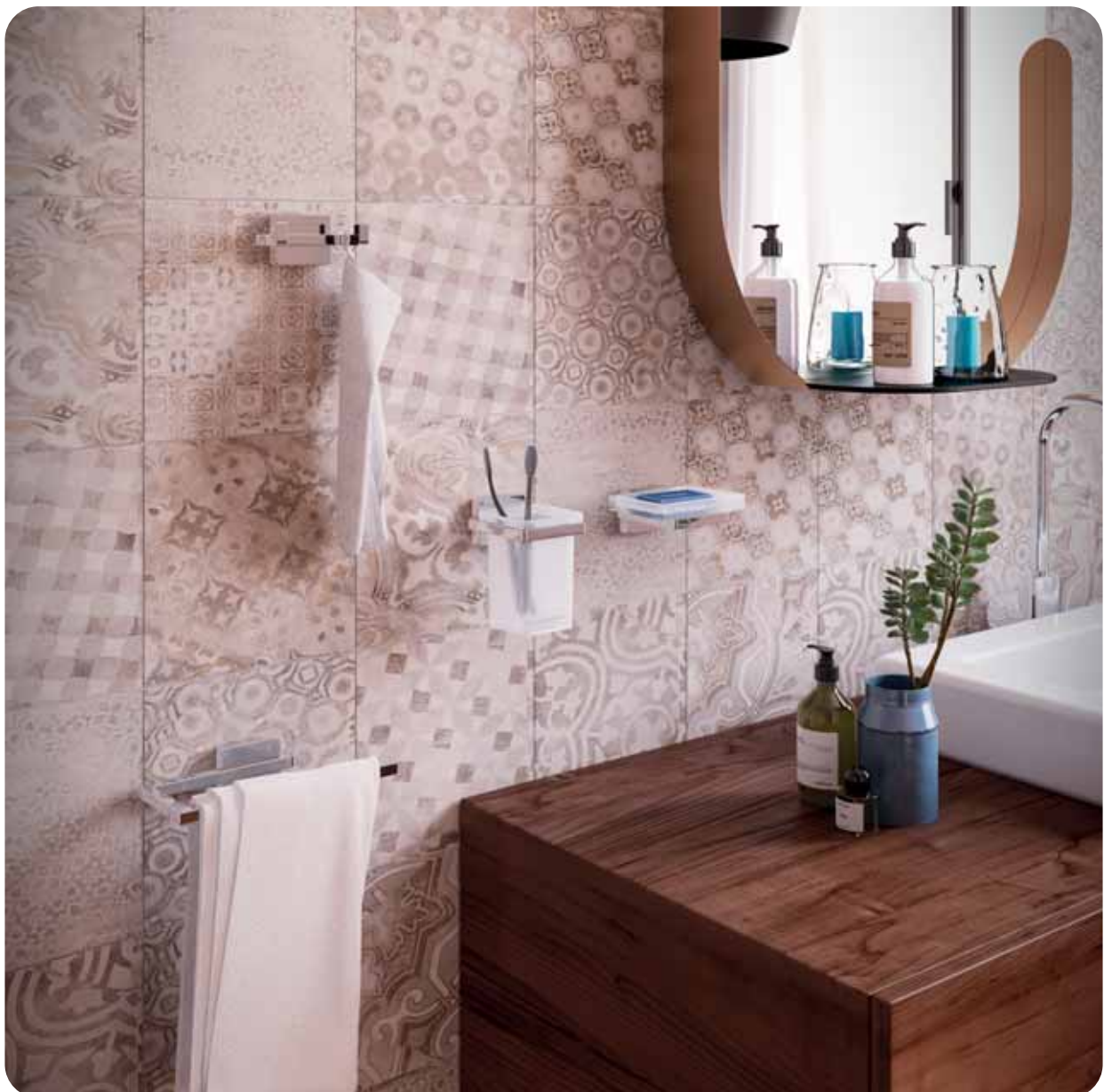



A201100CR
cm L. 7,5 x H. 11,6 x P. 9,4



A201110CR
cm L. 11,5 x H. 4,5 x P. 9,7



A201210CR
cm L. 9 x H. 4,5 x P. 4,7



A201250CR
cm L. 14 x H. 4,5 x P. 8,7



A20190ACR
cm L. 30 x H. 4,5 x P. 8,2

A20190BCR
cm L. 45 x H. 4,5 x P. 8,2

A20190CCR
cm L. 60 x H. 4,5 x P. 8,2



A201150CR
cm L. 42,8 x H. 6,2 x P. 3,3



A20189XCR
cm L. 20 x H. 4,5 x P. 8,7



A201090CR
cm L. 61 x H. 4,5 x P. 12,8



A201140CR
cm L. 9,5 x H. 37 x P. 11,2



A00006G
cm L. 6 x H. 13,5 x P. 3,5



Packaging in cartone
completamente riciclabile
Packaging made of fully
recyclable cardboard.
Packaging aus vollständig
recyclbarem Karton.
Emballage en carton
entièrement recyclable
Embalaje en cartón
totalmente reciclable

Wire

Serie realizzata in zama e acciaio, finitura cromo, corredi in vetro satinato
fissaggio con viti e tasselli inclusi, opzionale fissaggio ad incollo, colla venduta
separatamente

Series made of zamak and steel, chrome finish, satin glass complements
fixing set included (screws and plugs), optional glue fixing (glue sold separately)

Serie aus Zamak und Edelstahl, Chromausführung, Die Zubehörteile aus satiniertem
Glas Befestigungsset Enthalten (Schrauben und Dübel), optional montage zum
kleben (Kleber separat erhältlich)

Série en zamak et acier, finition chromée, pièces en verre satiné
kit de fixation inclus (vis et chevilles), optionnel fixation avec colle, colle vendue
séparément

Serie en zamak y acero, acabado cromado, complementos de vidrio satinado
fijación con tornillos incluidos, opcional fijación con pegamento (vendido
separadamente)

10
YEARS-GARANZIA
GUARANTEE





A200100CR
cm L. 7,6 x H. 11,2 x P. 11,5



A200110CR
cm L. 10,9 x H. 9,5 x P. 13,3



A200210CR
cm L. 8,4 x H. 5,4 x P. 5,1



A200250CR
cm L. 17 x H. 5,4 x P. 8,7



A20090ACR
cm L. 30 x H. 5,4 x P. 7,7

A20090BCR
cm L. 45 x H. 5,4 x P. 7,7
A20090CCR
cm L. 60 x H. 5,4 x P. 7,7



A200150CR
cm L. 43,2 x H. 6 x P. 2,7



A20089XCR
cm L. 23,2 x H. 5,4 x P. 8,7



A200090CR
cm L. 60,8 x H. 5,6 x P. 14,4



A200140CR
cm L. 11,5 x H. 38 x P. 15,5



A00006G
cm L. 6 x H. 13,5 x P. 3,5



Packaging in cartone
completamente riciclabile
Packaging made of fully
recyclable cardboard.
Packaging aus vollständig
recyclbarem Karton.
Emballage en carton
entièrement recyclable
Embalaje en cartón
totalmente reciclable

Smart

10
YEARS-GARANZIA
GUARANTEE

Serie realizzata in zama e acciaio, finitura cromo, corredi in vetro satinato
fissaggio con viti e tasselli inclusi

Series made of zamak and steel, chrome finish, satin glass complements
fixing set included (screws and plugs)

Serie aus Zamak und Edelstahl, Chromausführung, Die Zubehörteile aus satiniertem
Glas Befestigungsset Enthalten (Schrauben und Dübel)

Série en zamak et acier, finition chromée, pièces en verre satiné
kit de fixation inclus (vis et chevilles)

Serie en zamak y acero, acabado cromado, complementos de vidrio satinado
fijación con tornillos incluidos





A74100CR21CA
cm L. 8 x H. 10 x P. 11



A74110CR21CA
cm L. 12 x H. 7 x P. 13



A74200CRCA
cm L. 5 x H. 4 x P. 4



A74250CRCA
cm L. 18 x H. 4 x P. 7



A74150CRCA
cm L. 37 x H. 4 x P. 5



A7418ACRCA
cm L. 30 x H. 4 x P. 7

A7418BCRCA
cm L. 40 x H. 4 x P. 7

A7418CCRCA
cm L. 52 x H. 4 x P. 7



A74160CRCA
cm L. 16 x H. 17 x P. 4



A74090CR26
cm L. 53 x H. 4 x P. 14



A74140CR21CA
cm L. 18 x H. 4 x P. 7



Packaging in cartone
completamente riciclabile
Packaging made of fully
recyclable cardboard.

Packaging aus vollständig
recyclbarem Karton.

Emballage en carton
entièrement recyclable

Embalaje en cartón
totalmente reciclable

Lipari

Serie realizzata in zama e acciaio, finitura cromo, corredi in vetro trasparente fissaggio con viti e tasselli inclusi, opzionale fissaggio ad incollo, colla venduta separatamente

Series made of zamak and steel, chrome finish, transparent glass complements fixing set included (screws and plugs), optional glue fixing (glue sold separately)

Serie aus Zamak und Edelstahl, Chromausführung, Die Zubehörteile aus transparentem Glas Befestigungsset Enthalten (Schrauben und Dübel), optional montage zum kleben (Kleber separat erhältlich)

Série en zamak et acier, finition chromée, pièces en verre transparent kit de fixation inclus (vis et chevilles), optionnel fixation avec colle, colle vendue séparément

Serie en zamak y acero, acabado cromado, complementos de vidrio transparente fijación con tornillos incluidos, opcional fijación con pegamento (vendido separadamente)





A83100CR03
cm L. 8 x H. 11 x P. 9



A83110CR03
cm L. 14 x H. 7 x P. 14



A8321SCR
cm L. 7 x H. 7 x P. 6



A83150CR
cm L. 43 x H. 7 x P. 7



A8390ACR
cm L. 37 x H. 7 x P. 8
A8390BCR
cm L. 52 x H. 7 x P. 8



A8316TCR
cm L. 18 x H. 21 x P. 3



A83250CR
L. 20 x H. 7 x P. 8



A83140CR
cm Ø 9 x H. 41

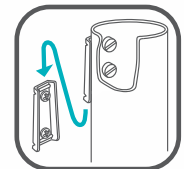

attacco sfilabile
sliding fastener
attache mobile
ausziehbare halterung
soporte movii



A00006G
cm L. 6 x H. 13,5 x P. 3,5



Complementi

Bathroom accessories

Care

Accessori ed ausili per il bagno, articoli progettati per offrire maggiore sicurezza ad anziani o utilizzatori con limitazioni motorie

Accessories and aids for the bathroom, designed to offer greater safety to elderly or people with special needs

Zubehöre und Hilfsmittel für das Badezimmer; Produkte, die älteren oder bewegungseingeschränkten Menschen mehr Sicherheit anbieten

Accessoires et aides pour la salle de bain, conçus pour offrir une plus grande sécurité aux personnes âgées ou aux utilisateurs à mobilité réduite

Accesorios y ayudas para el baño, productos pensados para ofrecer una mayor seguridad a los adultos mayores o a las personas con movilidad reducida





Sedile da vasca, realizzato in tecnopolimeri, alluminio e acciaio inox, che garantiscono massima igiene e una lunga durata, sedile regolabile in larghezza, design ergonomico, seduta antiscivolo posizionabile a 3 altezze diverse

Bathtub seat, made of technopolimers, aluminum and stainless steel, for maximum hygiene and durability, adjustable width, ergonomic design, anti-slip seat adjustable to 3 height positions

A106790AL001

cm L. 65-72 x H. 22 x P. 41



Sedile da muro, realizzato in tecnopolimeri, alluminio e acciaio inox, che garantiscono massima igiene e una lunga durata, design ergonomico, seduta antiscivolo, ribaltabile

Wall mounted seat, made of technopolimers, aluminum and stainless steel, for maximum hygiene and durability, anti-slip finish, ergonomic design, anti-slip & lift-up seat

A106790AL002

P 52 cm



Sedile da muro, realizzato in tecnopolimeri, alluminio e acciaio inox, che garantiscono massima igiene e una lunga durata, design ergonomico, seduta antiscivolo, ribaltabile

Wall mounted seat, made of technopolimers, aluminum and stainless steel, for maximum hygiene and durability, anti-slip finish, ergonomic design, anti-slip & lift-up seat

A106790AL003

P 30,5 cm



Sgabello da bagno, realizzato in tecnopolimeri e alluminio, che garantiscono massima igiene e una lunga durata, finitura antiscivolo

Bathroom seat, made of technopolimers and aluminum, for maximum hygiene and durability, anti-slip finish

A106791AL001

cm H 38

Kit snodo multifunzionali in plastica
multifunctional modular plastic kit system



A10699PL001
cm Ø 8,5 x 8



A10699PL002
cm Ø 8,5 x 7,5



A10691PL001
cm L. 30
A10691PL002
cm L. 45

A10691PL003
cm L. 60
A10691PL004
cm L. 100



A10690PL001
cm L. 30
A10690PL002
cm L. 45
A10693PL003
cm L. 60

Corrimani - grab bars



A10690AC001
cm L. 30 x 3,2
A10690AC002
cm L. 45 x 3,2

A10690AC003
cm L. 60 x 3,2
A10690AC004
cm L. 80 x 3,2

1.500N
(~150Kg)



A10690AX001
cm L. 30 x 3,2
A10690AX002
cm L. 45 x 3,2

A10690AX003
cm L. 60 x 3,2
A10690AX004
cm L. 80 x 3,2

1.500N
(~150Kg)



A10690AC005
cm Ø 3,2 x L 30 x 30

1.500N
(~150Kg)



A10690AX005
cm Ø 3,2 x L 30 x 30

1.500N
(~150Kg)

1.500N
(~150Kg)

A10690AC006

Ø 3,2 x L 30x60 cm - destra/right

A10690AC007

Ø 3,2 x L 30x60 cm - sinistra/left



1.500N
(~150Kg)

A10690AX006

Ø 3,2 x L 30x60 cm - destra/right

A10690AX007

Ø 3,2 x L 30x60 cm - sinistra/left



A10690AC008

cm Ø 3,2 x L. 70

1.250N
(~125Kg)



A10690AX008

cm Ø 3,2 x L. 70

1.250N
(~125Kg)

Alzawater - Raised toilet seat



A106790BL001

cm 36,5 x 45 x 10

Alzawater con sistema di bloccaggio laterale a vite che assicura un fissaggio stabile e sicuro realizzato in polipropilene, altezza 10 cm

Raised toilet seat with locking system, side clamps to ensure a stable and secure fastening, made of polypropylene, height 10cm



A106790BL002

cm 36,5 x 45 x 10

Alzawater con sistema di bloccaggio e coperchio, bloccaggio laterale a vite che assicura un fissaggio stabile e sicuro, realizzato in polipropilene, altezza 10cm

Raised toilet seat with locking system and lid, side clamps to ensure a stable and secure fastening, made of polypropylene, height 10cm



Gredos

Specchio da bagno a LED, design moderno, rettangolare 100x80 cm, installazione reversibile, orizzontale o verticale luce fredda 5500° K, W led 19.2, classe A++

LED bathroom mirror, modern design, rectangular 100x80 cm Reversible, horizontal or vertical installation Cold light 5500° K, W led 19.2, class A ++

LED Badspiegel, modernes Design, rechteckig 100x80 cm Reversible, horizontale oder vertikale Installation Kaltes Licht 5500°K, W led 19.2, Klasse A ++

Miroir LED pour la salle de bain, design moderne, rectangulaire 100x80 cm, Installation réversible, horizontale ou verticale Lumière froide 5500° K, W led 19.2, classe A ++

Espejo LED para baño, diseño moderno, rectangular 100x80 cm, Instalación reversible, horizontal o vertical Luz fría 5500°K, W led 19.2, clase A ++

AV661RET

cm 100 x 80 x 2,6

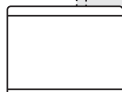

Iris

Specchio da bagno a led, design moderno tondo ø 80 cm
luce fredda 5500° k, w led 20.6, Classe F

LED bathroom mirror, modern design Round ø 80 cm
Cold light 5500 ° K, W led 20.6, class F

LED Badspiegel, modernes Design Runden ø 80 cm
Kaltes Licht 5500°K, W led 20.6, Klasse F

Miroir LED pour la salle de bain, design moderne Rond ø 80 cm
Lumière froide 5500 ° K, W led 20.6, classe F

Espejo LED para baño, diseño moderno Redondo ø 80 cm
Luz fría 5500°K, W led 20.6, clase F

AV662TON

cm ø 80 x 3,5

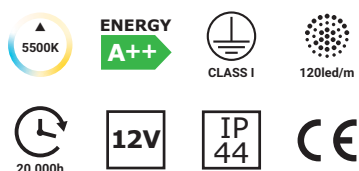

Eco one

Specchio da bagno a led, design moderno, quadrato 80x80 cm
luce fredda 5500° k, w led 6.2, Classe a++

LED bathroom mirror, modern design, Square 80x80 cm
Cold light 5500 ° K, W led 6.2, class A ++

LED Badspiegel, modernes Design, Quadrat 80x80 cm
Kaltes Licht 5500°K, W led 6.2, Klasse A ++

Miroir LED pour la salle de bain, design moderne, Carré 80x80 cm
Lumière froide 5500 ° K, W led 6.2, classe A ++

Espejo LED para baño, diseño moderno, Cuadrado 80x80 cm
Luz fría 5500°K, W led 6.2, clase A ++

AV660QUA

cm 80 x 80 x 2,9

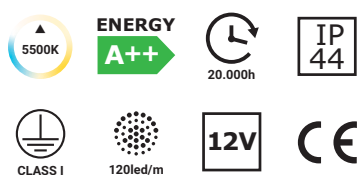

Specchi ingranditori



AV658ACR001

cm L. 19 x H. 38 x P. 9-55

Specchio ingranditore con braccio estensibile finitura cromo, doppio specchio 1x e ingranditore 2,5x orientabile a 360°, fissaggio a parete con viti e tasselli inclusi

Magnifying mirror with extending arm double face mirror 1x and magnifying 2.5x 360° swivel, chrome finish, wall fixing with screws and plugs included

Spiegel vergrößerung mit ausziehbarem Arm verchromt, Doppelspiegel 1x und Vergrößerung 2,5x 360° schwenkbar, Wandbefestigung mit Schrauben und Dübeln inklusive

Miroir grossissant avec bras extensible, finition chromée, miroir double 1x et grossissant 2,5x, pivotant à 360° fixation murale avec vis et chevilles inclus

Espejo de aumento con brazo extensible, acabado cromado, espejo doble 1x y aumento 2,5x, giratorio 360° montaje en la pared con tornillos incluidos



AV658BCR001

cm L. 25 x H. 33 x P. 34

Specchio ingranditore con doppio braccio a snodo, finitura cromo, doppio specchio 1x e ingranditore 2,5x, orientabile a 360°, fissaggio a parete con viti e tasselli inclusi

Magnifying mirror with double arm, double face mirror 1x and magnifying 2.5x, 360° swivel, chrome finish, wall fixing with screws and plugs included

Spiegel vergrößerung mit doppelt Arm, verchromt, Doppelspiegel 1x und Vergrößerung 2,5x, 360° schwenkbar, Wandbefestigung mit Schrauben und Dübeln inklusive

Miroir grossissant avec bras à double articulation, finition chromé, miroir double 1x et grossissant 2,5x, pivotant à 360°, fixation murale avec vis et chevilles inclus

Espejo de aumento con brazo doble, acabado cromado, espejo doble 1x y aumento 2,5x, giratorio 360°, montaje en la pared con tornillos incluidos

Daisy

Realizzato in abs bianco, specchio ingranditore 10x
 Made of white abs, magnifying 10x
 Aus weiss abs, vergrößerung 10x
 Réalisé en abs blanc, grossissant 10x
 Realizado en abs blanco, de aumento 10x

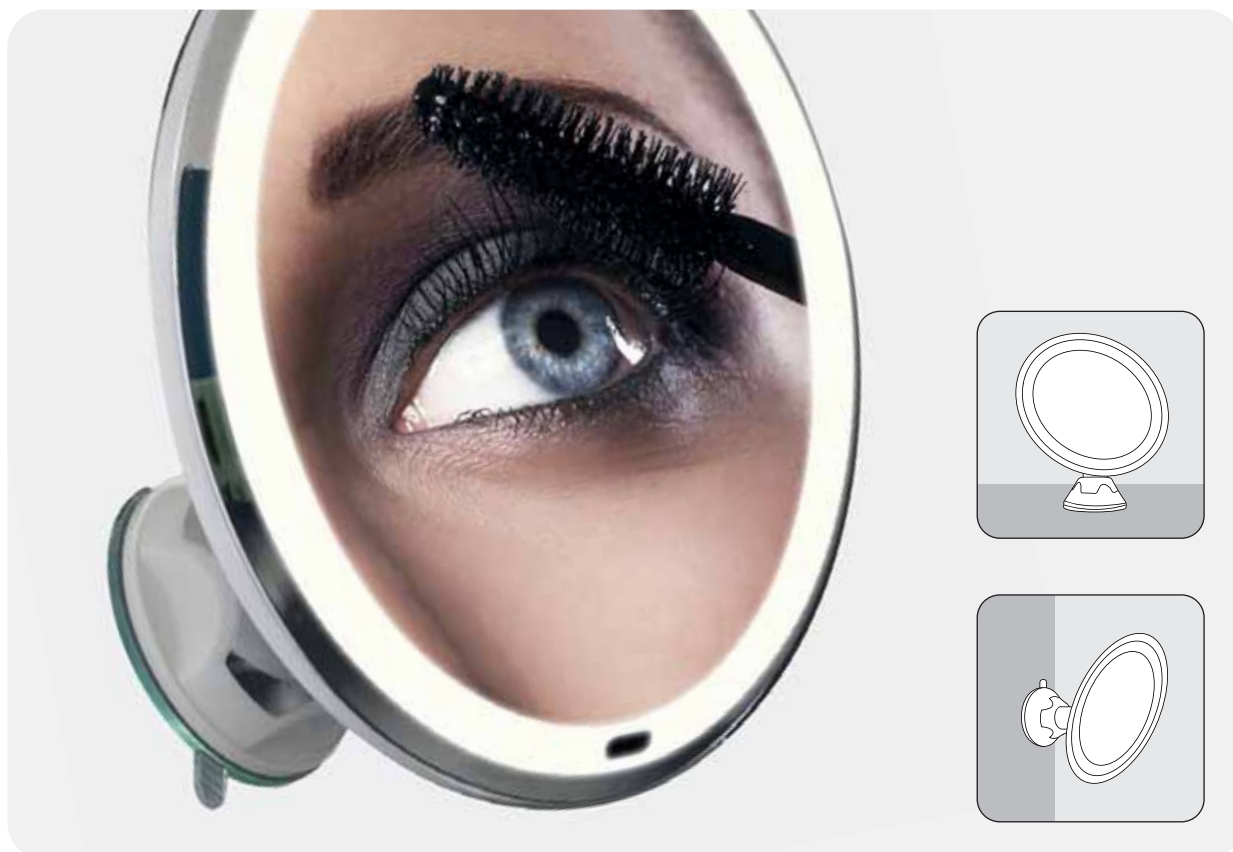
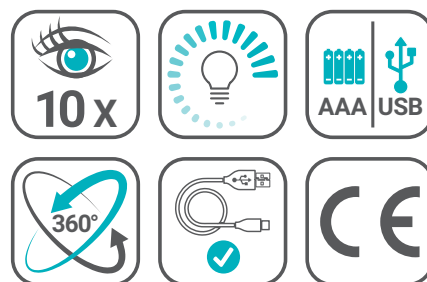

AV663VEN

cm L. 20 x H. 21 x P. 8



Specchio ingranditore 10x a Led, orientabile a 360° con ventosa, posizionabile su piano orizzontale o verticale, realizzato in Abs bianco, con 20 luci Led, alimentazione tramite usb (cavo incluso) o batterie (non incluse), regolazione dell'intensità della luce Led Touch

Cosmetic mirror 10x magnification, Led illuminated, 360° swivel rotation, with suction cup, for fastening onto vertical or horizontal surfaces, made of white Abs, with 20 Led lights, power supply through usb (cable included) or with batteries (non included), light intensity adjustment Led Touch

Kosmetikspiegel 10-fache vergrößerung mit led-beleuchtung verstellbar um 360° mit saugnapf zur befestigung an waage-oder senkrechten flächen aus weissem abs mit 20 Led-leuchten, stromversorgung über usb (Kabel enthalten) oder mit batterien (nicht enthalten), LED Touch Lichtintensitätseinstellung

Miroir grossissant 10x, avec éclairage led, orientable sur 360 degrés, avec ventouse, à fixer sans perçage sur des surfaces verticales ou horizontales, en abs blanc, avec 20 Led intégrés, chargement usb (câble inclus) ou à piles (non inclus), réglage de l'intensité lumineuse LED Touch

Espejo cosmético de aumento 10x, con luz Led, ajustable en 360 grados, con ventosa, para ajar sin perforar en superficies verticales u horizontales en abs blanco, con 20 leds, alimentación con pilas (no incluido) o a través del puerto usb (cable incluido), ajuste de intensidad de luz LED Touch

Clever



Piantana WC multifunzionale
 Multifunctional WC butler
 Multifunktionale WC-Kombi-Bürstengarnitur
 Serviteur WC multifonctionnel
 Conjunto portarrollos WC multifuncional

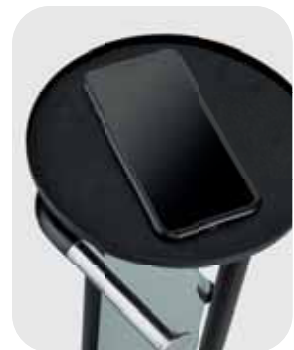

A113002NR

cm L. 22 x H. 71 x P. 22

Piantana WC multifunzionale, realizzata in acciaio e vetro satinato, finitura cromo/nero, bifacciale con portarotolo e pratica asta di stoccaggio rotoli, porta scopino incorporato, mensola appoggio antiscivolo

Multifunctional WC butler, made of steel and satin glass, black/chrome finish, with toilet paper holder and toilet paper storage, toilet brush holder, non-slip shelf

Multifunktionale WC-Kombi-Bürstengarnitur, aus Stahl und satinierem Glas, Ausführung schwarz/chrom, mit Papierrollenständer und Papierrollen Lagerung, Bürstengarnitur, rutschfeste Ablage

Serviteur WC multifonctionnel, en acier et verre satiné, finition noir/cromé, avec porte papier wc et stockeur papier, porte balai wc, étagère antidérapante

Conjunto portarrollos WC multifuncional, en acero y cristal satinado, acabado negro/cromado, portarrollos, con porta rollos de reserva, escobillero, estante antideslizante



FRONTE

RETRO

Piantane

Realizzata in metallo cromato.

Made of chrome metal.

Fabriqu  en m tal chrom .

Aus verchromtem Metall.

Fabricado de metal cromado.

DW

Vetro
Glass
Glas
Verre
Vidrio

DN

Nero
Black
Noire
Schwarz
Negro

QV085ADW

QV085ADN

cm L. 28 x H. 72 x P. 20

base in vetro temperato
tempered glass base
base en verre tremp 
Fu  aus Sicherheitsglas
base de vidrio templado



QV086ADW

QV086ADN

cm L. 51 x H. 82 x P. 23

base in vetro temperato
tempered glass base
base en verre tremp 
Fu  aus Sicherheitsglas
base de vidrio templado



QV085DCR

cm L. 49 x H. 82 x P. 20



QV086DCR

cm L. 20 x H. 72 x P. 20



Elegance

Serie realizzata in acciaio, finitura cromo/nero, garantito contro la ruggine, fissaggio con viti e tasselli inclusi

Series made of steel, black/chrome finish, rust free guarantee, fixing with screws and plugs included

Serie aus Stahl, Ausführung chrom/schwarz mit anti-rost-garantie, einschl. schrauben und dübel für die montage

Série en acier, finition chromée/noire, garantie anti-rouille, kit de fixation avec vis et chevilles inclus

Serie en acero, acabado cromo/negro, garantizado contra la oxidación, fijación con tornillos incluidos



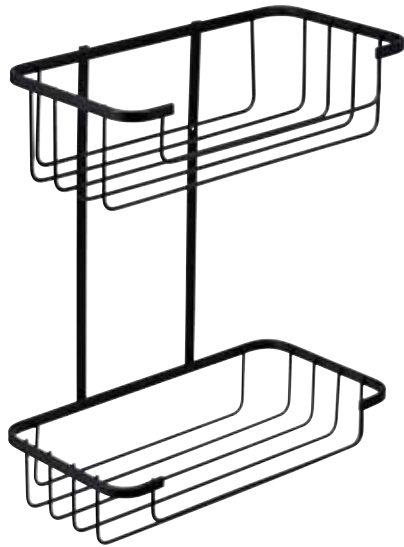

A114003NO
cm L. 25 x H. 31.6 x P. 12.8

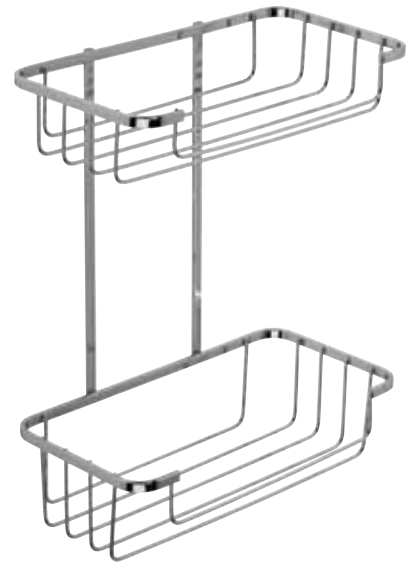

A114006CR
cm L. 25 x H. 31.6 x P. 12.8

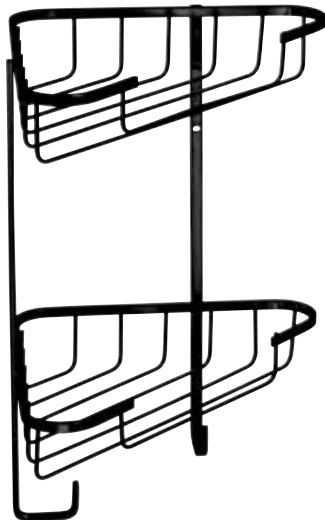

A114002NO
cm L. 25x H. 32.7 x P. 14.7



A114005CR
cm L. 25x H. 32.7 x P. 14.7



appendibile con gancio
hangs with hook
hängt mit Haken
accrochable avec crochet
colgante con gancho

A114001NO
cm L. 18 x H. 28 x P. 13



A114004CR
cm L. 18 x H. 28 x P. 13

Attractive

Serie realizzata in alluminio finitura cromo/nero, garantito contro la ruggine, fissaggio con viti e tasselli inclusi

Series made of aluminium, black/chrome finish, rust free guarantee, fixing with screws and plugs included

Serie aus aluminium, Ausführung chrom/schwarz mit anti-rost-garantie, einschl. schrauben und dübel für die montage

Série en aluminium, finition cromée/noire, garantie anti-rouille, kit de fixation avec vis et chevilles inclus

Serie en aluminio, acabado cromo/negro, garantizado contra la oxidación, fijación con tornillos incluidos

ATT
RAC
TIVE
PREMIUM
COLLECTION



**A111004NE**

cm L. 25 x H. 75 x P. 16,7

**A111004CR**

cm L. 25 x H. 75 x P. 16,7



appendibile con gancio
hangs with hook
hängt mit Haken
accrochable avec crochet
colgante con gancho

**MAXI**

larghezza 30 cm
width 30 cm
Breite 30 cm
largeur 30cm
ancho 30cm

**A111007NE**

cm L. 30 x H. 9 x P. 14

**A111007CR**

cm L. 30 x H. 9 x P. 14



A111002AN
cm L. 31 x H. 39 x P. 20,8



A111006NA
cm L. 31 x H. 39 x P. 20,8



A111002FR
cm L. 25,5 x H. 39 x P. 12,5



A111006NF
cm L. 25,5 x H. 39 x P. 12,5



A111001FR
cm L. 26 x H. 14 x P. 12,5



A111005NF
cm L. 26 x H. 14 x P. 12,5



A111001AN
cm L. 31 x H. 6 x P. 20,5



A111005NA
cm L. 31 x H. 6 x P. 20,5

Memory

Tappeto bagno memory, superficie: 100% poliestere, interno: memory foam per un maggiore comfort, fondo: pvc antiscivolo

Bath mat memory, outer material: 100% polyester, inner material: memory foam for great comfort, bottom layer: non-slip pvc

Rutschhemmende badematte memory, oberfläche: 100% polyester, innenmaterial: memory-schaum, untere schicht: rutschhemmendes pvc

Tapis de bain memory, surface: 100% polyester, intérieur: memory foam pour plus de confort, matière au dos: pvc antidérapant

Alfombra de baño memory, superficie: 100% poliéster, interior: memory foam aumentará el confort, reverso: en pvc antideslizante





TAME5080GS
cm 50 x 80



TAME5080GC
cm 50 x 80



TAME4060AC
cm 40 x 60



TAME4060BE
cm 40 x 60

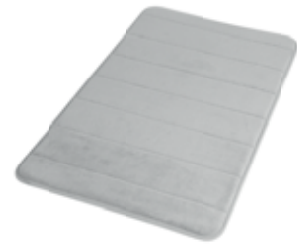

TAME4060GC
cm 40 x 60



TABA4575GR
cm 45 x 75



TABA4575AZ
cm 45 x 75



TAH04575VE
cm 45 x 75



TAH04575RO
cm 45 x 75



TAH04575GS
cm 45 x 75



TASA4575GC
cm 45 x 75



TASA4575BE
cm 45 x 75



TASA4575VE
cm 45 x 75

Wiper

Realizzato in polipropilene, fissaggio a parete con pratica ventosa
 Made in pp, with wall mounting suction bracket
 Aus pp, Wandmontage mit Saugnapf
 Réalisée en pp, montage mural avec des ventouses
 Realizado en pp, montaje en la pared con taza de aspiración

WW

Bianco
 White
 Blanc
 Weiß
 Blanco

NE

Nero
 Black
 Noire
 Schwarz
 Negro

GR

Grigio
 Gray
 Gris
 Grau
 Gris



TE0003WW

cm L. 23 x H. 3 x P. 22



TE0002NE

cm L. 23 x H. 3 x P. 22



TE0001GR

cm L. 23 x H. 3 x P. 22

Jack

Realizzato in resina
 Made of resin
 Réalisée en résine
 Hergestellt aus resina
 Realizado en resina

TR Trasparente
 Transparent
 Transparent
 Transparent
 Transparente

FX Fuxia
 Pink
 Fuchsia
 Fuchsia
 Fuchsia

BL Blu
 Blue
 Bleu
 Blau
 Azul

WW Grigio
 Gray
 Gris
 Grau
 Gris



A110200TR
 cm L. 6,4 x H. 11 x P. 8,5



A110200FX
 cm L. 6,4 x H. 11 x P. 8,5



A110200BL
 cm L. 6,4 x H. 11 x P. 8,5



A110200WW
 cm L. 6,4 x H. 11 x P. 8,5





Accessori da appoggio

Free standing
accessories

Deco

Realizzata in vetro
Made of glass
Réalisée en verre
Hergestellt aus Glas
Realizada en cristal

AM

Ambra
Amber
Ambre
Bernstein
Ámbar

TR

Trasparente
Transparent
Transparent
Transparent
Transparent



QL5100AM
QL5100TR

cm Ø 7,4 x H. 11,7



QL5110AM
QL5110TR

cm Ø 11,3 x H. 2,1



QL5120AM
QL5120TR

cm Ø 7,4 x H. 16,6



QL5140AM
QL5140TR

cm Ø 9,5 x H. 36,6

Diamond

Realizzata in vetro
Made of glass
Réalisée en verre
Hergestellt aus Glas
Realizada en cristal



QL8100AT
cm Ø 8,5 x H. 10,4



QL8110AT
cm Ø 11 x H. 2,5



QL8120AT
cm Ø 8,6 x H. 16,8



QL8140AT
cm Ø 9,8 x H. 35,5

Elba

Realizzata in vetro
Made of glass
Réalisée en verre
Hergestellt aus Glas
Realizada en cristal



QL2100AT
cm Ø 7,3 x H. 10,3



QL2110AT
cm L. 14,8 x H. 3 x P. 9,6



QL2120AT
cm Ø 6,9 x H. 20,1



QL2140AT
cm Ø 8,8 x H. 35,5

Floral

Realizzata in ceramica
Made of ceramic
Réalisée en céramique
Hergestellt aus keramik
Realizada en cerámica



QL3100WW
cm Ø 6,8 x H. 10,7



QL3110WW
cm L. 13,2 x H. 2 x P. 9



QL3120WW
cm Ø 6,6 x H. 18,4



QL3140WW
cm Ø 9,8 x H. 35,5

Folk

Realizzata in ceramica
 Made of ceramic
 Réalisée en céramique
 Hergestellt aus Keramik
 Realizada en cerámica



Blu/Bianco
 Blue/White
 Bleu/Blanc
 Blau/Weiß
 Azul/Blanco



Giallo/Bianco
 Yellow/White
 Jaune/Blanc
 Gelb/Weiß
 Amarillo/Blanco



QL4100BW
QL4100GW
 cm Ø 7,5 x H. 10,9



QL4110BW
QL4110GW
 cm L. 13 x H. 2,4 x P. 8,9



QL4120BW
QL4120GW
 cm Ø 8,1 x H. 15



QL4150BW
QL4150GW
 cm Ø 9 x H. 10,5



QL4140BW
QL4140GW
 cm Ø 9,7 x H. 35,5

Fossil

Realizzata in poliresina
Made of polyresin
Réalisée en polyresin
Hergestellt aus polyresin
Realizada en poliresina



QI3100GR
cm L. 9,2 x H. 9 x P. 4,7



QI3110GR
cm Ø 12 x H. 2



QI3120GR
cm L. 11 x H. 15,4 x P. 4,7



QI3140GR
cm Ø 9,5 x H. 35,5

Ink

Realizzata in ceramica
 Made of ceramic
 Réalisée en céramique
 Hergestellt aus Keramik
 Realizada en cerámica



QI2100WW
 cm Ø 7 x H. 10,4



QI2110WW
 cm L. 13,1 x H. 2,3 x P. 9



QI2120WW
 cm Ø 9 x H. 13,4



QI2150WW
 cm Ø 8,9 x H. 9,5



QI2140WW
 cm Ø 9,9 x H. 35,5

Marmor

Realizzata in vetro
Made of glass
Réalisée en verre
Hergestellt aus Glas
Realizada en cristal



QL6100SA
cm Ø 6,1 x H. 12



QL6110SA
cm Ø 12 x H. 2,6



QL6120SA
cm Ø 6,1 x H. 17,3



QL6140SA
cm Ø 8,5 x H. 37

Midnight

Realizzata in vetro
Made of glass
Réalisée en verre
Hergestellt aus Glas
Realizada en cristal



QI9100BL
cm Ø 7,1 x H. 10,7



QI9110BL
cm L. 13,9 x H. 1,5 x P. 8,9



QI9120BL
cm Ø 7,1 x H. 18,8



QI9140BL
cm Ø 7,9 x H. 35,8

Olivia

Realizzata in ceramica, finitura lucida/soft-touch
 Made of ceramic, glossy/soft-touch finish
 Réalisée en céramique, finition brillante/soft-touch
 Hergestellt aus keramik, Ausführung glänzendes/soft-touch
 Realizada en cerámica, acabado brillante/soft-touch

NE

Nero
 Black
 Noire
 Schwarz
 Negro

VS

Verde
 Green
 Vert
 Grün
 Verde



QH9100NE
QH9100VS
 cm Ø 7,2 x H. 10,6



QH9110NE
QH9110VS
 cm L. 13,3 x H. 1,9 x P. 9,2



QH9120NE
QH9120VS
 cm Ø 7,1 x H. 20,1



QH9160NE
QH9160VS
 cm Ø 9 x H. 10



QH9140NE
QH9140VS
 cm Ø 10,3 x H. 34

Onyx

Realizzata in poliresina
Made of polyresin
Réalisée en polyresin
Hergestellt aus polyresin
Realizada en poliresina



QI4100NE
cm L. 6,9 x H. 10 x P. 6,9



QI4110NE
cm L. 13,1 x H. 1,9 x P. 9



QI4120NE
cm L. 7,1 x H. 16,1 x P. 7,1



QI4140NE
cm L. 9,3 x H. 35,5 x P. 9,3

Opal

Realizzata in vetro
Made of glass
Réalisée en verre
Hergestellt aus Glas
Realizada en cristal



QI8100TR
cm Ø 7 x H. 10



QI8110TR
cm L. 10,1 x H. 2 x P. 10,1



QI8120TR
cm L. 8,1 x H. 17 x P. 8,1



QI8140TR
cm Ø 9,1 x H. 38

Rattan

Realizzata in ceramica
Made of ceramic
Réalisée en céramique
Hergestellt aus keramik
Realizada en cerámica



QI6100WW
cm L. 8,6 x H. 11,6 x P. 8,6



QI6110WW
cm L. 14,4 x H. 3,5 x P. 10,5



QI6120WW
cm L. 8,7 x H. 20 x P. 8,7



QI6140WW
cm L. 11,5 x H. 37,5 x P. 11,5

Retro

Realizzata in vetro
Made of glass
Réalisée en verre
Hergestellt aus Glas
Realizada en cristal



QL7100TR
cm Ø 7,1 x H. 10,2



QL7110TR
cm L. 15 x H. 2,8 x P. 11



QL7120TR
cm Ø 8 x H. 20,2



QL7140TR
cm Ø 10 x H. 36

Sidian

Realizzata in ceramica
Made of ceramic
Réalisée en céramique
Hergestellt aus Keramik
Realizada en cerámica



QI7100NE
cm Ø 7,3 x H. 9,9



QI7110NE
cm Ø 11,8 x H. 2,4



QI7120NE
cm Ø 7,3 x H. 19,8



QI7150NE
cm Ø 10,8 x H. 10,9



QI7140NE
cm Ø 10,6 x H. 37

Silk

Realizzata in poliresina
Made of polyresin
Réalisée en polyresin
Hergestellt aus polyresin
Realizada en poliresina



QL1100AZ
cm L. 10,3 x H. 9,8 x P. 5,9



QL1110AZ
cm L. 13 x H. 1,6 x P. 8,3



QL1120AZ
cm L. 8,5 x H. 14,8 x P. 6,5



QL1140AZ
cm L. 10 x H. 35,5 x P. 9,5

Stark

Realizzata in ceramica
Made of ceramic
Réalisée en céramique
Hergestellt aus keramik
Realizada en cerámica



QI5100CB
cm Ø 7,6 x H. 9,8



QI5110CB
cm Ø 10,8 x H. 3



QI5120CB
cm L. 11 x H. 15 x P. 6,3



QI5140CB
cm Ø 9,5 x H. 35

Gardena

Realizzata in ceramica
Made of ceramic
Réalisée en céramique
Hergestellt aus keramik
Realizada en cerámica



QH6100TO
cm Ø 8 x H. 9,5



QH6110TO
cm Ø 11 x H. 2,5



QH6120TO
cm Ø 8 x H. 16



QH6160TO
cm Ø 8 x H. 11



QH6140TO
cm Ø 10 x H. 36

Ebony

Realizzata in poliresina
Made of polyresin
Réalisée en polyresin
Hergestellt aus polyresin
Realizada en poliresina



QH1100NE
cm Ø 7,3 x H. 10



QH1110NE
cm L. 14 x H. 2,3 x P. 9



QH1120NE
cm Ø 7,3 x H. 18,2



QH1160NE
cm Ø 9 x H. 12



QH1140NE
cm Ø 10 x H. 35

Palm

Realizzata in poliresina
 Made of polyresin
 Réalisée en polyresin
 Hergestellt aus polyresin
 Realizada en poliresina



QH8100WW
 cm L. 8,5 x H. 9 x P. 7



QH8110WW
 cm L. 14,5 x H. 2,5 x P. 11



QH8120WW
 cm L. 11,5 x H. 16 x P. 6



QH8140WW
 cm L. 12,5 x H. 34,5 x P. 10,5

Emerald

Realizzata in ceramica
Made of ceramic
Réalisée en céramique
Hergestellt aus keramik
Realizada en cerámica



QH2100NO
cm Ø 7,5 x H. 9,5



QH2110NO
cm Ø 11 x H. 2,5



QH2120NO
cm Ø 7,5 x H. 17,5



QH2140NO
cm Ø 10,2 x H. 35

Grid

Realizzata in poliresina / ferro
 Made of polyresin / steel
 Réalisée en polyresin / acier
 Hergestellt aus polyresin / stahl
 Realizada en poliresina / acero

NE

Nero
 Black
 Noire
 Schwarz
 Negro

WW

Bianco
 White
 Blanc
 Weiß
 Blanco



QG1100NE
QG1100WW
 cm Ø 7 x H. 10,7



QG1110NE
QG1110WW
 cm L 14 x P 8,7 x H. 2,5



QG1120NE
QG1120WW
 cm Ø 7 x H. 18,7



QG1140NE
QG1140WW
 cm Ø 10 x H. 36

Crystal

Realizzata in vetro
Made of glass
Réalisée en verre
Hergestellt aus Glas
Realizada en cristal



Erogatore in metallo
Metal pump
Pompe savon en métal
Pumpe aus Metall
Dosificador en metal



QF9100BL
cm Ø 8,5 x H. 10



QF9110BL
cm L. 16 x H. 4 x P. 11



QF9120BL
cm Ø 8 x H. 18,5



QF9140BL
cm Ø 9 x H. 39

Dora

Realizzata in vetro
Made of glass
Réalisée en verre
Hergestellt aus Glas
Realizada en cristal



Erogatore in metallo
Metal pump
Pompe savon en métal
Pumpe aus Metall
Dosificador en metal



QF6100TO
cm Ø 8,5 x H. 10



QF6110TO
cm L. 16 x H. 4 x P. 11



QF6120TO
cm Ø 8 x H. 18,5



QF6140TO
cm Ø 9 x H. 39

Melody

Realizzata in vetro
Made of glass
Réalisée en verre
Hergestellt aus Glas
Realizada en cristal



Erogatore in metallo
Metal pump
Pompe savon en métal
Pumpe aus Metall
Dosificador en metal



QF8100GR
cm Ø 7,5 x H. 11



QF8110GR
L. 14 x H. 2,5 x P. 8,5



QF8120GR
cm Ø 7,5 x H. 20



QF8140GR
cm Ø 9 x H. 39

Summer

Realizzata in vetro
Made of glass
Réalisée en verre
Hergestellt aus Glas
Realizada en cristal



Erogatore in metallo
Metal pump
Pompe savon en métal
Pumpe aus Metall
Dosificador en metal



QF7100AZ
cm Ø 8,5 x H. 10



QF7110AZ
cm L. 16 x H. 4 x P. 11



QF7120AZ
cm Ø 8 x H. 18,5



QF7140AZ
cm Ø 9 x H. 39

Rock

Realizzata in ceramica
Made of ceramic
Réalisée en céramique
Hergestellt aus keramik
Realizada en cerámica



QG3100GR
cm L. 7 x H. 10 x P. 7



QG3110GR
cm L. 10,3 x H. 2,3 x P. 7,8



QG3120GR
cm L. 6,7 x H. 16,5 x P. 6,7



QG3140GR
cm Ø 9 x H. 36

Next

Realizzata in poliresina
Made of polyresin
Réalisée en polyresin
Hergestellt aus polyresin
Realizada en poliresina



QE4100WW
cm L. 7 x H. 11 x P. 7



QE4110WW
cm L. 13 x H. 2,3 x P. 8,5



QE4120WW
cm L. 7 x H. 18,5 x P. 7



QE4140WW
cm L. 8,5 x H. 35 x P. 8,5

Cool

Realizzata in poliresina
Made of polyresin
Réalisée en polyresin
Hergestellt aus polyresin
Realizada en poliresina



QE3100LE
cm L. 6,2 x H. 10 x P. 6,2



QE3110LE
cm L. 12,5 x H. 2 x P. 7



QE3120LE
cm L. 6,5 x H. 16 x P. 8,2



QE3140LE
cm L. 9 x H. 34,5 x P. 9

Perl

Realizzata in poliresina, con decori mosaico effetto madreperla
 Made of polyresin, with mosaic decorations mother-of-pearl effect
 Réalisée en polyresin, avec decorations en mosaïque effet de nacre
 Hergestellt aus polyresin, mit mosaik-ornament, perlmutter-effekt
 Realizada en poliresina, con decoraciones en mosaico efecto de madreperla



QD9100MA
 cm L. 7 x H. 10,5 x P. 7



QD9110MA
 cm L. 12 x H. 3 x P. 7,8



QD9120MA
 cm L. 7 x H. 19 x P. 7



QD9140MA
 cm L. 9 x H. 38 x P. 9

Street

Realizzata in cemento
Made of cement
Réalisée en ciment
Aus zement
Realizada en cemento



QD5100GN
cm L. 6,5 x H. 9,5 x P. 6,5



QD5110GN
cm L. 12,5 x H. 2,2 x P. 8,2



QD5120GN
cm L. 6,7 x H. 16 x P. 6,7



QD5140GN
cm L. 11 x H. 40 x P. 11

Ramses

Realizzata in cemento
Made of cement
Réalisée en ciment
Aus zement
Realizada en cemento



QD3100MA
cm L. 6,5 x H. 11 x P. 6,5



QD3110MA
cm L. 13,5 x H. 2,3 x P. 9



QD3120MA
cm L. 6,5 x H. 17 x P. 6,5



QD3140MA
cm L. 9,5 x H. 38,5 x P. 9,5

Mystique

Realizzata in ceramica
Made of ceramic
Réalisée en céramique
Hergestellt aus Keramik
Realizada en cerámica



A101100ICE000
cm L. 7,5 x H. 10 x P. 7,5



A101110ICE000
cm L. 12 x H. 2,5 x P. 8



A101120ICE000
cm L. 7 x H. 18 x P. 7



A101140ICE000
cm L. 10,5 x H. 37 x P. 10,5

Glitter

Realizzata in ceramica
 Made of ceramic
 Réalisée en céramique
 Hergestellt aus keramik
 Realizada en cerámica

RA

Rosa ramato
 Copper rose
 Kupferrosa
 Rose cuivre
 Finición en cobre

AS

Argento satinato
 Silver matt
 Silber matt
 Argent satiné
 Plata satinado



QF2100RA
QF2100AS
 cm Ø 7,5 x H. 9,5



QF2110RA
QF2110AS
 cm Ø 13 x H. 3,6



QF2120RA
QF2120AS
 cm Ø 10 x H. 15



QF2140RA
QF2140AS
 cm Ø 11,5 x H. 36

Damasco

Realizzata in poliresina
 Made of polyresin
 Réalisée en polyresin
 Hergestellt aus polyresin
 Realizada en poliresina

RM

Rame/Marrone
 Copper/Brown
 Cuivre/Brun
 Kupfer/Braun
 Cobre/Marrón

WK

Bianco/argento
 White/silver
 Blanc/argent
 Weiß/silber
 Blanco/plateado



QD6100WK
QD6100RM
 cm Ø 6 x H. 11



QD6110WK
QD6110RM
 cm L. 13 x H. 2 x P. 9



QD6120WK
QD6120RM
 cm Ø 6,5 x H. 20



QD6140WK
QD6140RM
 cm Ø 9,5 x H. 34,5

Stone

Realizzata in resina. Utilizzo di vernici atossiche.
 Made of resin. Use of atoxic laquers.
 Réalisée en résine. Utilisation de vernis non toxiques
 Hergestellt aus resina. Gebrauch von ungiftigen lacken
 Realizada en resina. Utilizacion de pinturas no toxicas



A102100IMP000
 cm L. 7 x H. 12 x P. 7



A102110IMP000
 cm L. 12,5 x H. 3 x P. 9



A102120IMP000
 cm L. 7 x H. 18,5 x P. 7



A102140IMP000
 cm L. 12 x H. 38,5 x P. 12

Layer

Realizzata in poliresina
 Made of polyresin
 Réalisée en polyresin
 Hergestellt aus polyresin
 Realizada en poliresina

AQ

Acquamarina
 Acquamarine
 Aigue-marine
 Aquamarin
 Aguamarina

MA

Marrone
 Brown
 Brun
 Braun
 Marrón



QD7100AQ
QD7100MA
 cm Ø 7,5 x H. 11

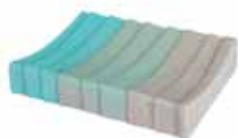

QD7110AQ
QD7110MA
 cm L. 12,5 x H. 2 x P. 8,5



QD7120AQ
QD7120MA
 cm Ø 7,5 x H. 19



QD7140AQ
QD7140MA
 cm Ø 9,5 x H. 35

Maya

Realizzata in ceramica
Made of ceramic
Réalisée en céramique
Hergestellt aus keramik
Realizada en cerámica



AQC100WW003
cm Ø 9 x H. 11,5



AQC110WW003
cm L 13,5 x H. 3 x P. 9



AQC120WW003
cm L 9 x H 18 x P 7



AQC140WW003
cm L 11 x H 37 x P 8,5

Bowling

Realizzata in resine termoplastiche
 Made of thermoplastic resin
 Réalisée en thermoplastique
 Hergestellt aus kunststoff
 Realizada en resinas termoplásticas

NE

Nero
 Black
 Noire
 Schwarz
 Negro

WW

Bianco
 White
 Blanc
 Weiß
 Blanco



QB3100NE
QB3100WW

cm L. 7 x H. 12 x P. 7



QB3110NE
QB3110WW

cm L. 14 x H. 4 x P. 10



QB3120NE
QB3120WW

cm L. 7 x H. 18 x P. 8



QB3140NE
QB3140WW

cm L. 12 x H. 38 x P. 12

Bridge

Realizzata in plastica
 Made of plastic
 Réalisée en plastique
 Hergestellt aus kunststoff
 Realizada en plástico



Bianco
 White
 Blanc
 Weiß
 Blanco



Argento
 Silver
 Argent
 Silber
 Plata



QF3100WW
QF3100WK
 cm Ø 7,2 x H. 11,8



QF3110WW
QF3110WK
 cm Ø 11 x H. 3



QF3120WW
QF3120WK
 cm Ø 7,2 x H. 14,7



QF3140WW
QF3140WK
 cm Ø 9,6 x H. 38

Style

Realizzata in resine termoplastiche
 Made of thermoplastic resin
 Réalisée en thermoplastique
 Hergestellt aus kunststoff
 Realizada en resinas termoplásticas

01

Bronzo
 Bronze
 Bronze
 Bronze
 Bronze

00

Bianco
 White
 Blanc
 Weiß
 Blanco



A103100IMP001
A103100IMP000
 cm Ø 7,5 x H. 9,5



A103110IMP001
A103110IMP000
 cm L. 12,5 x H. 3,5 x P. 8,5



A103120IMP001
A103120IMP000
 cm Ø 7,5 x H. 16



A103140IMP001
A103140IMP000
 cm 9,5 x 9,5 x H. 38

Tower

Realizzata in plastica
 Made of plastic
 Réalisée en plastique
 Hergestellt aus kunststoff
 Realizada en plástico

GR Grigio
 Gray
 Gris
 Grau
 Gris

WW Bianco
 White
 Blanc
 Weiß
 Blanco



QF1100GR
QF1100WW
 cm Ø 8 x H. 10



QF1110GR
QF1110WW
 cm L 13 x 8,5 x H. 2,5



QF1120GR
QF1120WW
 cm Ø 8 x H. 13



QF1140GR
QF1140WW
 cm Ø 13 x H. 36

Kubik

Realizzata in plastica
 Made of plastic
 Réalisée en plastique
 Hergestellt aus kunststoff
 Realizada en plástico

BE

Beige
 Beige
 Beige
 Beige
 Beige

WW

Bianco
 White
 Blanc
 Weiß
 Blanco



QG2100BE
QG2100WW
 cm L 7 x P 7 x H. 9,5



QG2110BE
QG2110WW
 cm L 11 x P 11 x H. 2,4



QG2120BE
QG2120WW
 cm L 7 x P 7 x H. 12



QG2150BE
QG2150WW
 cm L 18 x P 18 x H. 25



QG2140BE
QG2140WW
 cm L 9,5 x P 9,5 x H. 35

Fibi

Realizzata in ceramica
Made of ceramic
Réalisée en céramique
Hergestellt aus keramik
Realizada en cerámica



QC7100
cm Ø 7 x H. 11



QC7110
cm Ø 11 x H. 3



QC7120
cm Ø 7 x H. 17,5



QC7140
cm Ø 10 x H. 37



Box doccia New plus

Sono i dettagli che fanno la differenza
Details matter.

Les détails qui font la différence.

Am wichtigsten stehen die details.

Son los detalles que hacen la diferencia.

I box doccia New plus sono una soluzione ottimale per qualsiasi bagno e abbinano alla perfezione qualità, funzionalità e stile moderno. Installabile su piatti doccia o a pavimento

The New plus shower enclosures are an optimal solution for any bathroom and perfectly combine quality, functionality and modern style. Can be installed on shower trays or on the floor

Die Duschabtrennungen New plus sind eine optimale Lösung für jedes Badezimmer und vereinen perfekt Qualität, Funktionalität und modernen Stil. Kann auf Duschwannen oder auf dem Boden installiert werden

Les parois de douche New plus sont une solution optimale pour les salles de bain et combinent parfaitement qualité, fonctionnalité et style moderne. Peut être installés sur des receveurs de douche ou au sol

Las mamparas de ducha New plus son una solución óptima para cualquier baño y combinan a la perfección calidad, funcionalidad y estilo moderno. Se puede instalar en platos de ducha o en el suelo.



La qualità del prodotto / the quality of product / la qualité du produit / die qualität der produkte / la calidad del producto



Maniglia allungata dal design moderno

Extended handle with a modern design
Langer Griff in modernem Design
Poignée allongée au design moderne
Pomo alargado con un diseño moderno



Modelli con maniglia orizzontale portasciugamani

Models with horizontal handle as towel holder
Modelle mit horizontalem Griff Handtuchhalter
Modèles avec poignée horizontale porte-serviettes
Modelos con pomo horizontal estante toallas



Porte sganciabili per facile pulizia

Detachable doors for an easy cleaning
Aushängbare Türen zur einfachen Reinigung
Portes décrochables pour nettoyer facilement
Puertas desmontables para limpiar fácilmente



Scorrimento facilitato grazie ai cuscinetti a sfera

Easy sliding thanks to the door rollers
Vereinfachte Öffnung dank die Rollen
Coulissement facilité grâce aux rouleaux
Fácil deslizamiento gracias a los rodillos



Profili con tappi cromati di copertura

Profiles with cover chromed caps
Profilen mit verchromten Abdeckungsstopfen
Profils avec capuchons chromés de couvertur
Perfiles con tapones cromados de cubierta

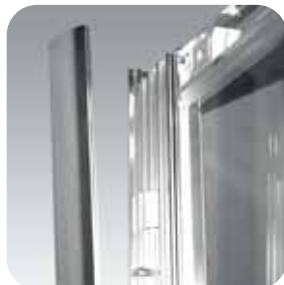

Profili di copertura delle viti di fissaggio

Cover profiles for the fixing screws
Profilen zur Abdeckung der Schrauben
Profils de couverture pour les vis de fixation
Perfiles de cubierta para los tornillos de fijación



Porte regolabili mediante un'apposita vite

Doors can be calibrated thanks to a screw
Türen mit Spezialschraube verstellbar
Portes réglables avec un vis spécial
Puertas regulables mediante tornillo especial



Tappi di copertura cromati a "L"

Cover chromed caps with "L" shape
Verchromten L-Stopfen bedeckt
Capuchons chromés avec la forme de "L"
Tapones cromados con forma de "L"

Telaio / frame / profilée
rahmen / bastidor

Vetri / glass / verres
glas / vidrios

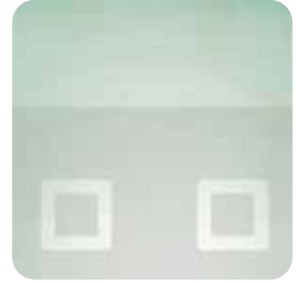

CR

Cromato lucido
Chrome polished
Chromé brillant
Chromiert glänzend
Cromado lustroso

WY

Bianco verniciato
White varnished
Blanc verni
Weiß lackiert
Blanco pintado

01

Trasparente
Transparent
Transparent
Klarglas
Transparente

55

Serigrafato kubo
Printed kubo
Sérigraphié kubo
Bedruckt kubo
Serigrafado kubo

La qualità del prodotto / the quality of product / la qualité du produit
die qualität der produkte / la calidad del producto

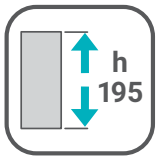

Altezza standard
Standard height
Hauteur standard
Standard Höhe
Altura estándar

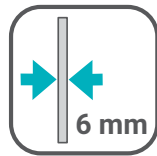

Spessore vetro
Glass thickness
Épaisseur verre
Glas stärke
Espesor vidrio

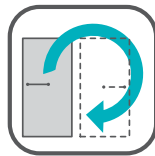

reversibile
Reversible
réversible
Reversibel
reversible



Porte sganciabili
Detachable doors
Portes décrochables
Aushängbare Türen
desmontables

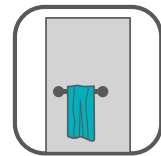

Maniglia
portasalviette
Handle towel holder
Porte-serviettes
Griffe
Handtuchhalter
Tiradores toalleros



B0380CR
Profilo aggiuntivo
Extra profile
Zusatzprofil Profil
complémentaire
Perfil adicional



Estensibilità
Extensibility
Extensibilité
Anpassungsfähigkeit
Extensibilidad

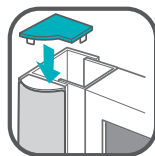

Elementi copertura
Covering elements
Éléments de cache
Abdeckelmenten
Recubrimiento

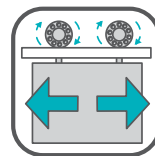

Scorrimento facilitato
Easy sliding
Coulissement
Facilité
Vereinfachte
Öffnung
Fácil deslizamiento



Chiusura magnetica
Magnetic closure
Fermeture
magnétique
Magnetverschluss
Cierre magnético



Porta scorrevole ad angolo quadrata / sliding corner door
 porte coulissante d'angle / eckEinstieg / puerta corredera angular

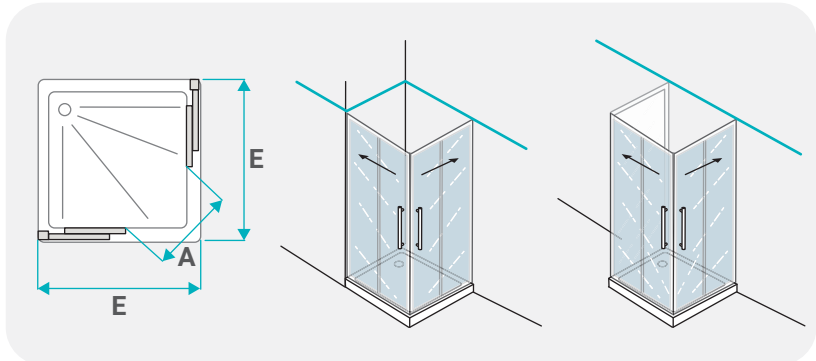
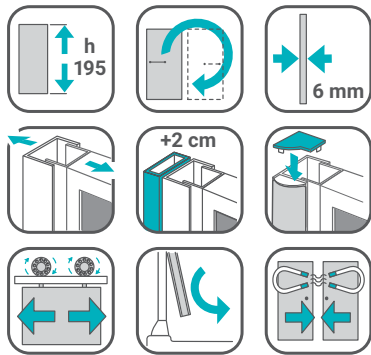

A	E		01		55
cm 41	cm 77-79	CR	B0302PCR01	CR	B0302PCR55
cm 48	cm 87-89	CR	B0304PCR01	CR	B0304PCR55

Porta scorrevole ad angolo rettangolare / sliding corner door / porte coulissante
 d'angle / eckEinstieg / puerta corredera angular

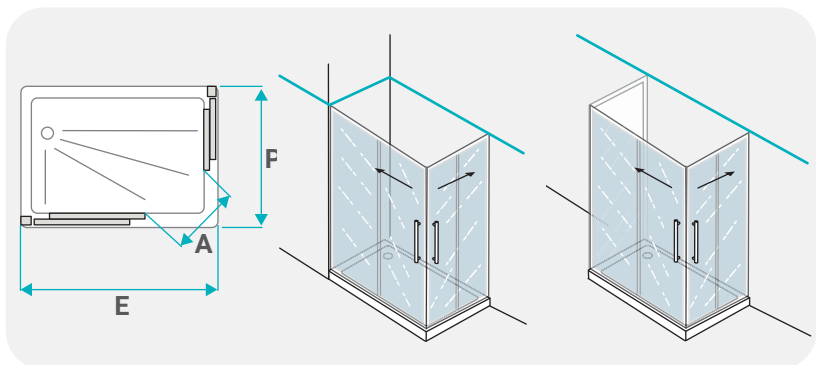
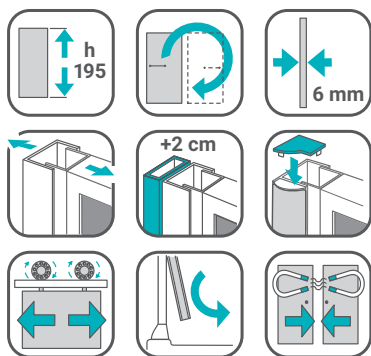

A	E	P		01		55
cm 42	cm 87-89	cm 67-69	CR	B0307PCR01	CR	B0307PCR55
cm 46	cm 97-99	cm 67-69	CR	B0308PCR01	CR	B0308PCR55



Porta scorrevole semicircolare / semicircular sliding door / coulissante semi-circulaire / halbkreise schiebetür / puerta corredera semicircular

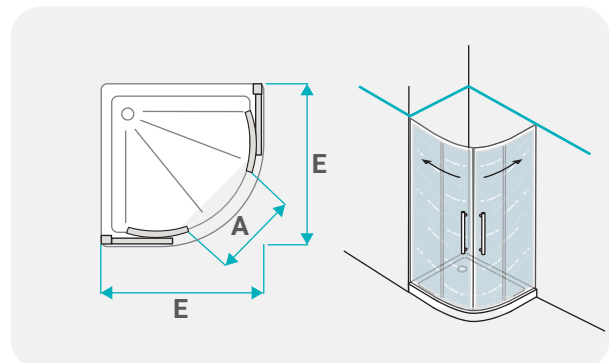
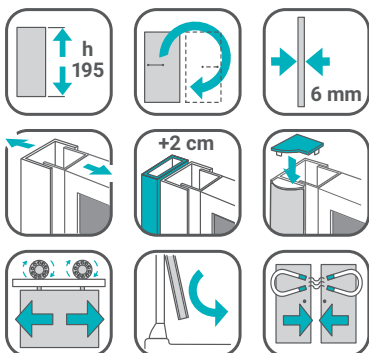

A	E		01	55
cm 42	cm 77 - 79	CR	B0322PCR01	-
cm 54	cm 87 - 89	CR	B0324PCR01	-



Scorrevole in linea / sliding door / porte coulissante
schiebetür - puerta corredera

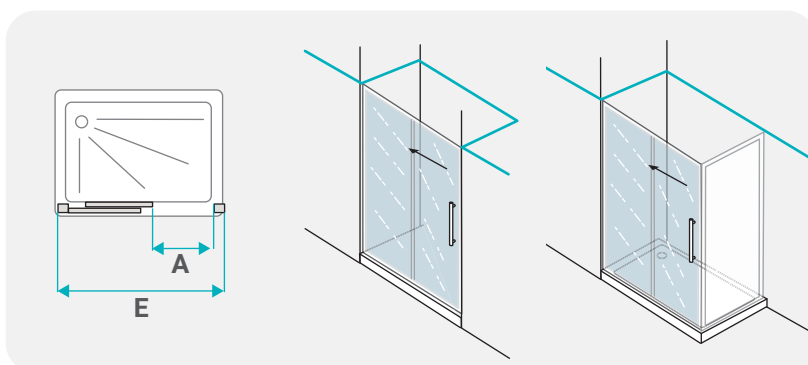
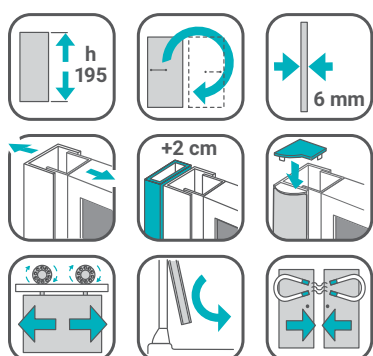

A	E		01		55
cm 39	cm 97-101	CR	B0331PCR01	CR	B0331PCR55
cm 41	cm 101-105	-	-	CR	B0332PCR55
cm 49	cm 117-121	CR	B0333PCR01	CR	B0333PCR55
cm 59	cm 137-141	CR	B0335PCR01	CR	B0335PCR55
cm 69	cm 157-161	CR	B0338PCR01	CR	B0338PCR55
		-	-	WY	B0338PWY55
cm 74	cm 167-171	CR	B0339PCR01	CR	B0339PCR55
		WY	B0339PWY01	WY	B0339PWY55



Porta battente / pivot door / porte battante
drehtür / puerta batiente

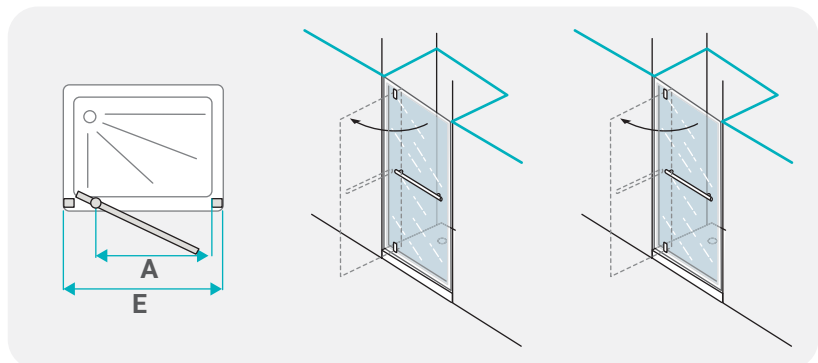
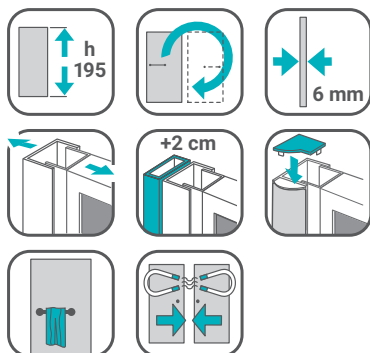

A	E		01		55
cm 50	cm 67-71	CR	B0340PCR01	CR	B0340PCR55
cm 60	cm 77-81	CR	B0342PCR01	CR	B0342PCR55
cm 70	cm 87-91	CR	B0344PCR01	CR	B0344PCR55



Porta battente con elemento fisso / pivot door with fix side / porte tournante avec paroi / flügeltür mit festseite / puera batiente pared fija

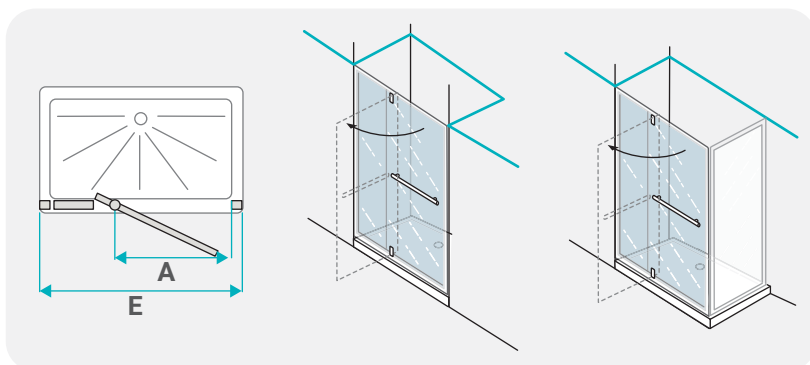
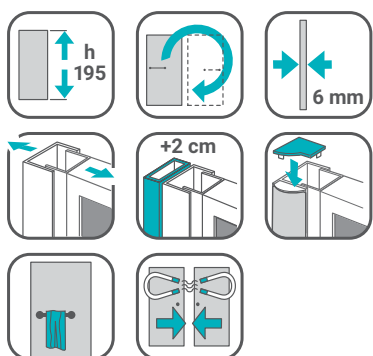

A	E		01		55
cm 69	cm 117-121	CR	B0347PCR01	-	-
cm 69	cm 137-141	CR	B0348PCR01	-	-



Porta a soffietto / folding door / porte a' soufflet
falttür / puerta feulle

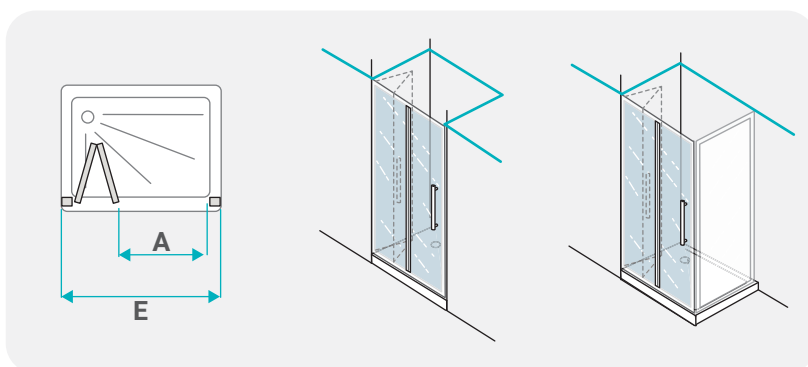
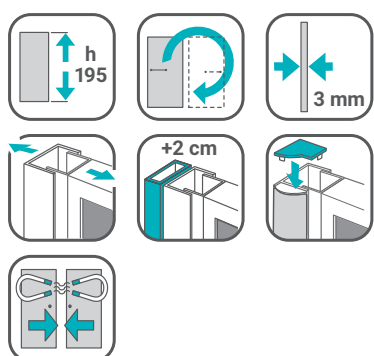



A	E		01		55
cm 52	cm 77-81	CR	B0372PCR01	-	-
cm 62	cm 87-91	CR	B0374PCR01	-	-
cm 72	cm 97-101	CR	B0376PCR01	-	-

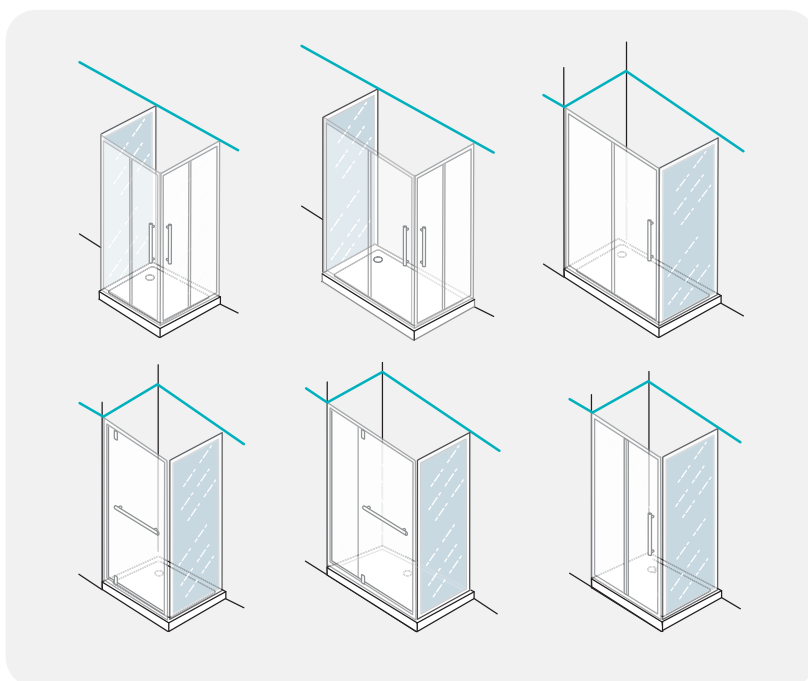
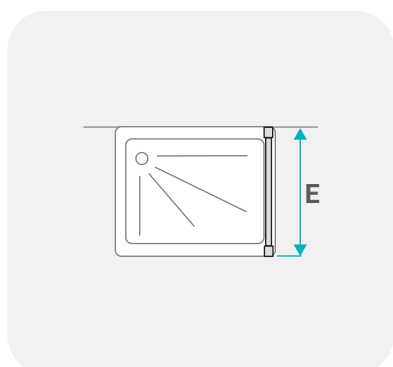
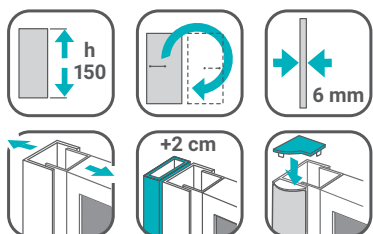

Parete fissa / fixed panel / paroi fixe / feste wand / pared fija



E	T	 01		 55
cm 67-69	CR	B0350PCR01	CR	B0350PCR55
	WY	B0350PWY01	-	-
cm 77-79	CR	B0352PCR01	CR	B0352PCR55
cm 87-89	CR	B0354PCR01	CR	B0354PCR55



Parete per vasca / bath tub wall / paroi baignoire / badewannewand
pared bañera

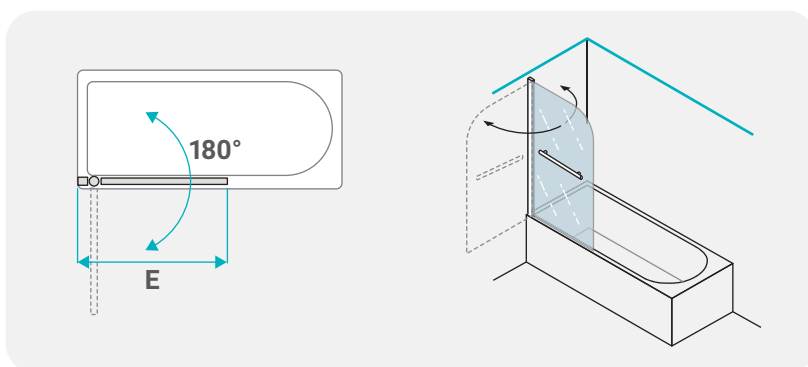
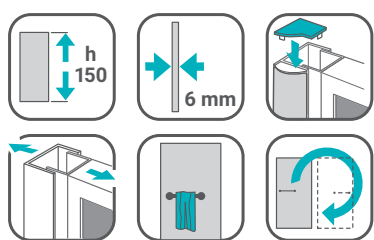

E		01
cm 90-92	CR	B0385VCR01



Parete per vasca con elemento fisso / bath tub wall fix side / paroi baignoire partie fixe / badewannenwand festseite / pared bañera lado fijo

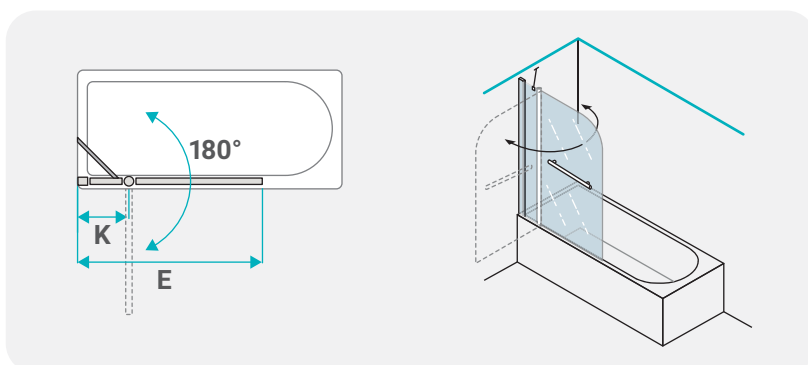
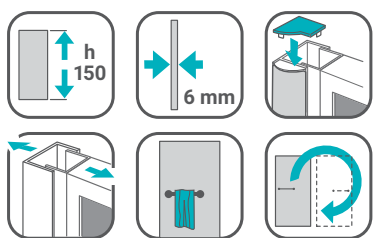

K	E	CR	 01
cm 30	cm 120 - 122	CR	B0387VCR01

CONDIZIONI GENERALI DI VENDITA

STIPULA DEL CONTRATTO

L'invio da parte del compratore di un ordine al venditore comporta l'applicazione al contratto di vendita delle presenti condizioni generali. Il venditore si riserva il diritto di accettare o rifiutare l'ordine ricevuto. Le offerte fatte da agenti, rappresentanti ed ausiliari del commercio del venditore non sono per lui impegnative né a quando non siano confermate dal venditore stesso.

PREZZI

I prezzi sono soggetti a variazione e non sono impegnativi senza la conferma scritta.

RESA DELLA MERCE

La fornitura della merce si intende franco fabbrica del venditore, salvo patto contrario, per cui trasporto e assicurazione sono a carico del compratore e ciò anche quando sia stabilito che la spedizione venga curata dal venditore. I rischi relativi alla fornitura saranno a carico del compratore dal momento in cui i prodotti lasciano lo stabilimento.

TERMINI DI CONSEGNA

I termini di consegna indicati dal venditore si intendono sempre approssimativi e non danno il diritto al compratore di annullare l'ordinazione, restando inoltre esclusa ogni qualsiasi responsabilità da parte del venditore per danni diretti o indiretti che possono derivare dal ritardo della fornitura.

GARANZIA

Il venditore garantisce la conformità dei prodotti forniti: si intende che essi corrispondono a quanto stabilito nel contratto per quantità, qualità e tipo. Il venditore non risponde dei difetti di conformità dei prodotti dovuti all'usura di quelle parti, che per loro natura sono soggette a usura rapida e continua.

RECLAMI

Il compratore è tenuto a verificare l'assenza di vizi e la conformità dei prodotti. I reclami devono essere fatti per iscritto tramite lettera raccomandata indicante nei dettagli i vizi e le non conformità contestate, entro e non oltre i 15 giorni dal ricevimento della merce, pena la decadenza della garanzia.

LIMITAZIONE DI RESPONSABILITÀ DEL VENDITORE

L'eventuale richiesta di risarcimento di qualsiasi danno al compratore, salvo colpa. Tale danno non potrà superare il prezzo della fattura dei prodotti contestati.

PAGAMENTI

I pagamenti devono essere fatti entro i termini stabiliti e si intendono netti al domicilio del venditore. Si precisa che qualsiasi ritardo o irregolarità nel pagamento darà al venditore, senza alcun preavviso, il diritto di sospensione delle forniture o di risolvere i contratti in corso, anche se non relativi alle forniture in questione. Trascorse le scadenze convenute saranno conteggiati gli interessi moratori nella misura del tasso di interesse bancario corrente. Si precisa che la fornitura consegnata resta di proprietà del venditore fin al momento del completo pagamento del prezzo.

FORO COMPETENTE

In caso di controversia è espressamente riconosciuta la sola competenza al Foro di Bergamo.

IDRO-BRIC SpA

si riserva il diritto di apportare modifiche che migliorative agli oggetti riprodotti in catalogo. Tali modifiche migliorative possono intervenire senza che ciò possa costituire elemento di contestazione. Tutti gli articoli presenti nel catalogo, sono identificati da un codice prodotto con relativa immagine, dimensioni, materiali, ecc. Tutte queste informazioni sono fornite a titolo informativo e non assumono in alcun modo carattere contrattuale. Esse potrebbero subire modifiche che migliorative nel corso del tempo, che possono intervenire senza che ciò possa costituire elemento di contestazione.

IDRO-BRIC SpA

reserves the right to implement improvements to the objects which are reproduced in the catalogue. Such improvements can be implemented anytime, without such improvements being subject of any claims. All the products presented in the catalogue are identified by an item code number, by the specific product image, dimensions, materials etc. All the information and materials presented are intended to be used for informational purposes only and cannot in any way be deemed to result in any contractual obligation. Thus, they can be improved over time, without such improvements being subject of any claims.

IDRO-BRIC SpA

behält sich das Recht vor, an den Produkten im vorliegenden Katalog Verbesserungen vorzunehmen. Solche Verbesserungen können jederzeit vorgenommen werden, ohne dass in diesem Fall irgendwelche Ersatzansprüche oder andere Ansprüche entstehen. Alle Produkte im Katalog werden mit einer Artikelnummer, mit der entsprechenden Produktabbildung, bzw. mit Angaben über Abmessungen, Materialien etc. versehen. Alle diese Informationen und Angaben dienen ausschließlich Informationszwecken und führen zu keinen vertraglichen Verpflichtungen. Sie können dementsprechend im Laufe der Zeit verbessert werden, ohne dass in diesem Fall irgendwelche Ersatzansprüche oder andere Ansprüche entstehen.

IDRO-BRIC SpA

se réserve le droit d'apporter des améliorations aux produits présentés dans le catalogue. De telles améliorations peuvent être apportées à tout moment, sans que ça puisse constituer une raison pour des prétentions aux dommages-intérêts. Tous les produits présentés dans le catalogue sont identifiés par un code de référence, par l'image du produit, respectivement par les dimensions, les matériaux etc. Toutes ces informations sont fournies uniquement à titre d'information et ne peuvent en aucun cas être considérées comme ayant un caractère contractuel, elles pouvant être modifiées ou améliorées avec le temps, sans que ça puisse constituer une raison pour des prétentions aux dommages-intérêts.

CONDITIONS GÉNÉRALES DE VENTE

CONTRAT

L'envoi d'une commande de la part de l'acheteur au vendeur comporte l'application des présentes conditions générales au contrat de vente. Le vendeur se réserve le droit d'accepter ou de refuser la commande reçue. Les offres des agents, représentants et auxiliaires du commerce du vendeur ne sont pas contraignantes pour lui jusqu'au moment de la confirmation du vendeur même.

RIX

Les prix sont soumis à variations et ils ne sont pas contraignants sans la confirmation écrite.

LIVRAISON DE LA MARCHANDISE

La livraison de la marchandise est départ usine du vendeur, sauf accord contraire, par conséquent le transport et l'assurance sont à la charge de l'acheteur, même quand il est établi que la expédition est gérée par le vendeur. Les risques liés à la fourniture seront à la charge de l'acheteur dès que les produits quittent l'usine du vendeur.

DÉLAIS DE LIVRAISON

Les délais de livraison indiqués par le vendeur sont toujours approximatifs et ne donnent pas à l'acheteur le droit de annuler la commande, et de plus s'exonère le vendeur de toute responsabilité pour dommages directs ou indirects pouvant provenir du retard de la livraison.

GARANTIE

Le vendeur garantit la conformité des produits fournis: ils correspondent à ce que a été établie dans le contrat en ce qui concerne la quantité, qualité et type. Le vendeur n'est pas responsable de défauts de conformité des produits dus à l'usure des pièces, qui par nature sont sujettes à usure rapide et constante.

RÉCLAMATION

L'acheteur doit vérifier l'absence de défaut et la conformité des produits. Les réclamations doivent être transmises par écrit par courrier recommandé indiquant en détail les défauts et la nonconformité contestés au plus tard dans 15 jours de la réception de la marchandise, sous peine de la perte de la garantie.

LIMITATION DE LA RESPONSABILITÉ DU VENDEUR

L'eventuelle demande d'indemnisation des défauts ne peut pas dépasser le prix en nature des produits contestés.

PAGEMENTI

Les paiements doivent être effectués dans les délais fixés et ils sont départ usine du vendeur. Chaque retard ou paiement irrégulier donnera au vendeur le droit, sans préavis, d'arrêter les fournitures ou de mettre fin au contrats en cours, même s'ils ne sont relatifs aux fournitures en question. Après l'échéance convenue les intérêts moratoires seront comptabilisés selon le taux d'intérêt bancaire courant. La fourniture livrée reste la propriété du vendeur jusqu'au moment du paiement complet du prix.

JURIDICTION COMPÉTENTE

En cas de litige est expressément reconnue la compétence exclusive au tribunal de Bergamo.

VERKAUFSBEDINGUNGEN

VERTRAGSABSCHLUSS

Die Bestellung des Kunden an den Verkäufer bewirkt die Anwendung der folgenden Verkaufsbedingungen. Der Verkäufer behält sich das Recht vor, die Bestellung anzunehmen oder abzulehnen. Angebote die von Agenten, Vertretern oder Verkaufshelfern gemacht worden sind, sind nicht verbindlich bis zur endgültigen Bestätigung durch den Verkäufer.

PREISE

Preise koennen Aenderungen unterliegen und sind erst nach schriftlicher Bestätigung verbindlich.

WARENLIEFERUNG

Die Lieferung der Waren versteht sich ab Werk, wenn nicht anders vereinbart. Aus diesem Grund

sind Transport und Versicherung auf Kosten des Käufers, auch wenn der Transport vom Verkäufer organisiert ist. Alle mit der Spedition verbundenen Risiken sind zu Lasten des Kunden.

LIEFERTERMINE

Die vom Verkäufer angegebenen Liefertermine sind nicht verbindlich und geben dem Kunden damit kein Recht von der Bestellung zurückzutreten. Der Verkäufer lehnt jede Verantwortung für direkte und indirekte Schäden des Kundens auf Grund von verspäteten Lieferungen ab.

GARANTIE

Der Verkäufer garantiert die Konformität der gelieferten Ware, das heisst, dass diese mit der bestellten Ware in Menge, Qualität und Art übereinstimmt. Der Verkäufer garantiert nicht für die Konformität der Teile, die üblicherweise anfällig für Verschleiss sind.

REKLAMATIONEN

Der Kunde ist dazu verpflichtet, die Integrität und Konformität der Produkte zu kontrollieren. Eventuelle Reklamationen müssen schriftlich innerhalb von 15 Tagen per Einschreiben eingereicht werden. Dieser Brief muss alle Details über eventuelle Defekte enthalten. Sollte dies nicht eingehalten werden, verfällt die Garantie.

HAFTUNGSBESCHRÄNKUNGEN DES VERKÄUFERS

Jede mögliche Schadensersatzverpflichtung des Verkäufers ist limitiert auf den Verkaufspreis des bestellten Produktes.

ZAHLUNGEN

Die Zahlungen müssen innerhalb der vereinbarten Termine erfolgen und ohne zusätzliche Bankkosten für den Verkäufer. Es wird betont, dass jede Verspätung oder irreguläre Zahlung dem Verkäufer das Recht gibt, ohne jede Ankündigung weitere Lieferungen zu unterbrechen oder vom Vertrag zurückzutreten. Nach Ablauf der Zahlungsfrist werden Zinsen berechnet, die dem momentanen Bankzinsatz entsprechen. Es wird ausserdem betont, dass die gelieferte Ware bis zur kompletten Zahlung im Besitz des Verkäufers bleibt.

GERICHTSSTAND

Im Falle einer Streitfrage ist ausschliesslich das Gericht von Bergamo zuständig.



IDRO-BRIC s.p.A

Via dell'Industria, 4/b

24040 Casirate d'Adda (BG) - Italy

Tel. +39 0363 326690

Fax +39 0363 326710

info@idrobric.it

www.idrobric.it - www.aquasanit.it