

New plus

Sono i dettagli che fanno la differenza

Details matter.

Les détails qui font la différence.

Am wichtigsten stehen die details.

Son los detalles que hacen la diferencia.

I box doccia New plus sono una soluzione ottimale per qualsiasi bagno e abbinano alla perfezione qualità, funzionalità e stile moderno. Installabile su piatti doccia o a pavimento

The New plus shower enclosures are an optimal solution for any bathroom and perfectly combine quality, functionality and modern style. Can be installed on shower trays or on the floor

Die Duschatbrennungen New plus sind eine optimale Lösung für jedes Badezimmer und vereinen perfekt Qualität, Funktionalität und modernen Stil. Kann auf Duschwannen oder auf dem Boden installiert werden

Les parois de douche New plus sont une solution optimale pour les salles de bain et combinent parfaitement qualité, fonctionnalité et style moderne. Peut être installés sur des receveurs de douche ou au sol

Las mamparas de ducha New plus son una solución óptima para cualquier baño y combinan a la perfección calidad, funcionalidad y estilo moderno. Se puede instalar en platos de ducha o en el suelo.





La qualità del prodotto / the quality of product / la qualité du produit / die qualität der produkte / la calidad del producto



Maniglia allungata dal design moderno

Extended handle with a modern design
Langer Griff in modernem Design
Poignée allongée au design moderne
Pomo alargado con un diseño moderno



Modelli con maniglia orizzontale portasciugamani

Models with horizontal handle as towel holder
Modelle mit horizontalem Griff Handtuchhalter
Modèles avec poignée horizontale porte-serviettes
Modelos con pomo horizontal estante toallas



Porte sganciabili per facile pulizia

Detachable doors for an easy cleaning
Aushängbare Türen zur einfachen Reinigung
Portes décrochables pour nettoyer facilement
Puertas desmontables para limpiar fácilmente



Scorrimento facilitato grazie ai cuscinetti a sfera

Easy sliding thanks to the door rollers
Vereinfachte Öffnung dank die Rollen
Coulissement facilité grâce aux rouleaux
Fácil deslizamiento gracias a los rodillos



Profili con tappi cromati di copertura

Profiles with cover chromed caps
Profilen mit verchromten Abdeckungsstopfen
Profils avec capuchons chromés de couvertur
Perfiles con tapones cromados de cubierta

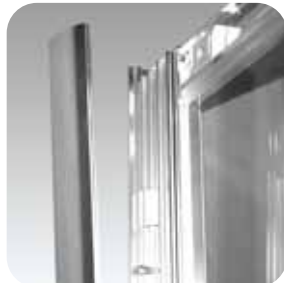

Profili di copertura delle viti di fissaggio

Cover profiles for the fixing screws
Profilen zur Abdeckung der Schrauben
Profils de couverture pour les vis de fixation
Perfiles de cubierta para los tornillos de fijaxo



Porte regolabili mediante un'apposita vite

Doors can be calibrated thanks to a screw
Türen mit Spezialschraube verstellbar
Portes réglables avec un vis spécial
Puertas regulables mediante tornillo especial



Tappi di copertura cromati a "L"

Cover chromed caps with "L" shape
Verchromten L-Stopfen bedeckt
Capuchons cromés avec la forme de "L"
Tapones cromados con forma de "L"

Telaio / frame / profilée
rahmen / bastidor

Vetri / glass / verres
glas / vidrios



CR

Cromato lucido
Chrome polished
Chromé brillant
Chromiert glänzend
Cromado lustroso



WY

Bianco verniciato
White varnished
Blanc verni
Weiß lackiert
Blanco pintado



01

Trasparente
Transparent
Transparent
Klarglas
Transparente



55

Serigrafato kubo
Printed kubo
Sérigraphié kubo
Bedruckt kubo
Serigrafado kubo

La qualità del prodotto / the quality of product / la qualité du produit
die qualität der produkte / la calidad del producto

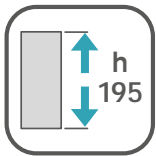

Altezza standard
Standard height
Hauteur standard
Standard Höhe
Altura estándar

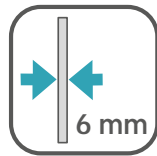

Spessore vetro
Glass thickness
Épaisseur verre
Glas stärke
Espesor vidrio

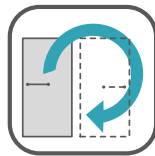

reversibile
Reversible
réversible
Reversibel
reversible



Porte sganciabili
Detachable doors
Portes décrochables
Aushängbare Türen
desmontables

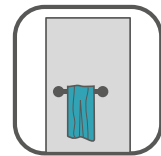

Maniglia
portasalviette
Handle towel holder
Porte-serviettes
Griffe
Handtuchhalter
Tiradores toalleros



B0380CR
Profilo aggiuntivo
Extra profile
Zusatzprofil Profil
complémentaire
Perfil adicional



Estensibilità
Extensibility
Extensibilité
Anpassungsfähigkeit
Extensibilidad



Elementi copertura
Covering elements
Éléments de cache
Abdeckelmenten
Recubrimiento

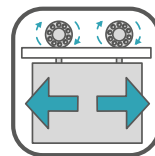

Scorrimento facilitato
Easy sliding
Coulissement
Facilité
Vereinfachte
Öffnung
Fácil deslizamiento



Chiusura magnetica
Magnetic closure
Fermeture magnétique
Magnetverschluss
Cierre magnético



Porta scorrevole ad angolo quadrata / *sliding corner door*
porte coulissante d'angle / eckeinstieg / puerta corredera angular

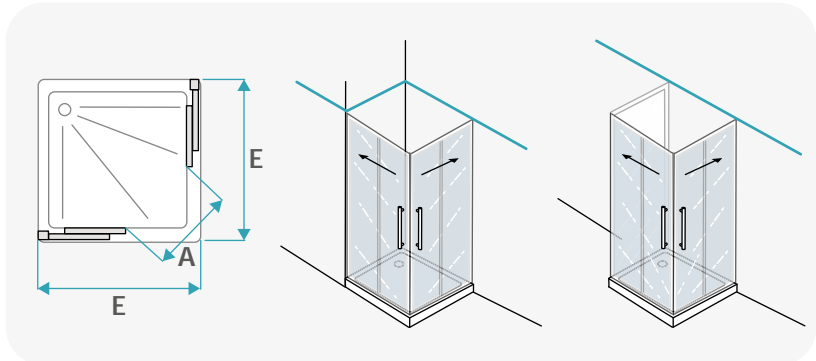
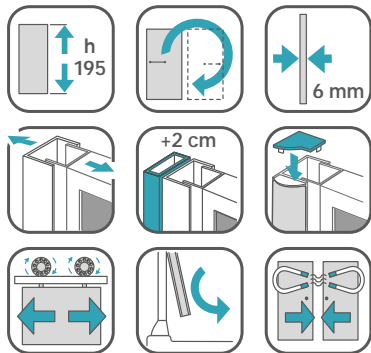

A	E		01		55
cm 41	cm 77-79	CR	B0302PCR01	CR	B0302PCR55
cm 48	cm 87-89	CR	B0304PCR01	CR	B0304PCR55

Porta scorrevole ad angolo rettangolare / *sliding corner door* / *porte coulissante d'angle / eckeinstieg / puerta corredera angular*

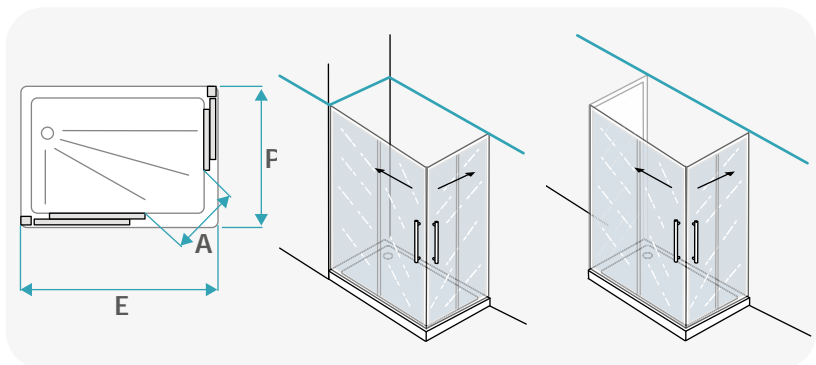
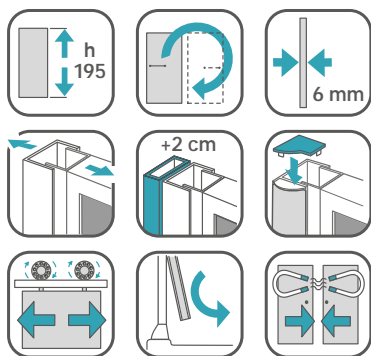

A	E	P		01		55
cm 42	cm 87-89	cm 67-69	CR	B0307PCR01	CR	B0307PCR55
cm 46	cm 97-99	cm 67-69	CR	B0308PCR01	CR	B0308PCR55



Porta scorrevole semicircolare / *semicircular sliding door* / *coulissante semi-circulaire* / *halbkreise schiebetür* / *puerta corredera semicircular*

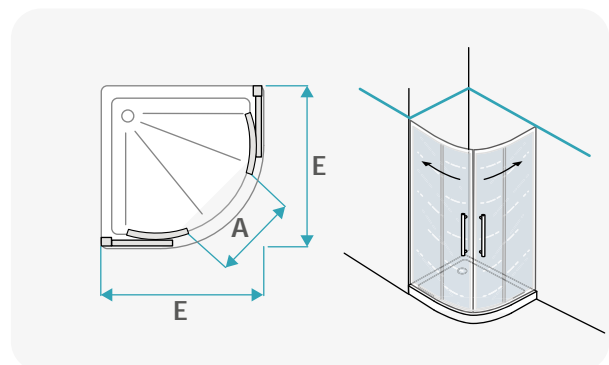
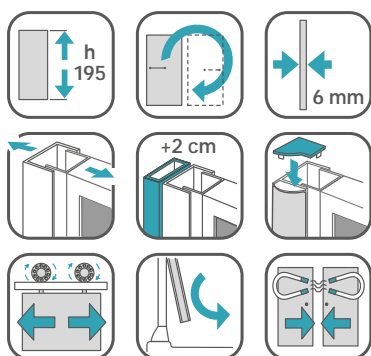

A	E		01	55
cm 42	cm 77 - 79	CR	B0322PCR01	-
cm 54	cm 87 - 89	CR	B0324PCR01	-



Scorrevole in linea / sliding door / porte coulissante / schiebetür - puerta corredera

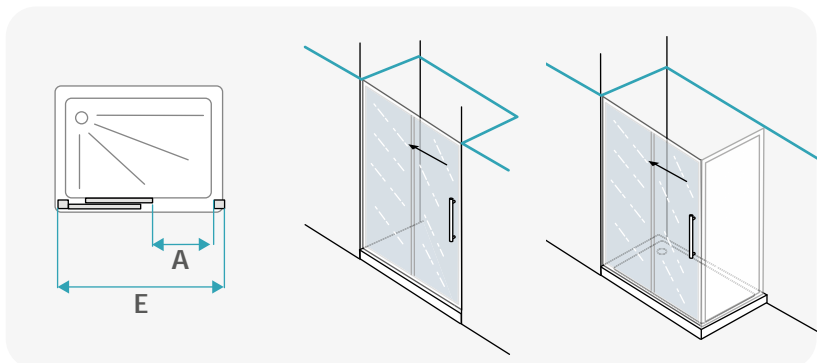
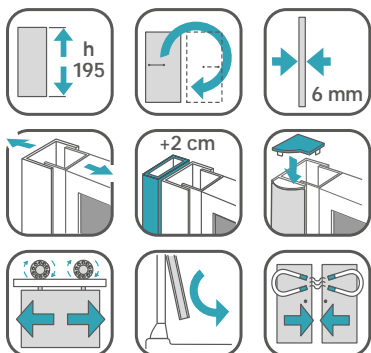

A	E		01		55
cm 39	cm 97-101	CR	B0331PCR01	CR	B0331PCR55
cm 41	cm 101-105	-	-	CR	B0332PCR55
cm 49	cm 117-121	CR	B0333PCR01	CR	B0333PCR55
cm 59	cm 137-141	CR	B0335PCR01	CR	B0335PCR55
cm 69	cm 157-161	CR	B0338PCR01	CR	B0338PCR55
		-	-	WY	B0338PWY55
cm 74	cm 167-171	CR	B0339PCR01	CR	B0339PCR55
		WY	B0339PWY01	WY	B0339PWY55



Porta battente / pivot door / porte battante
drehtür / puerta batiente

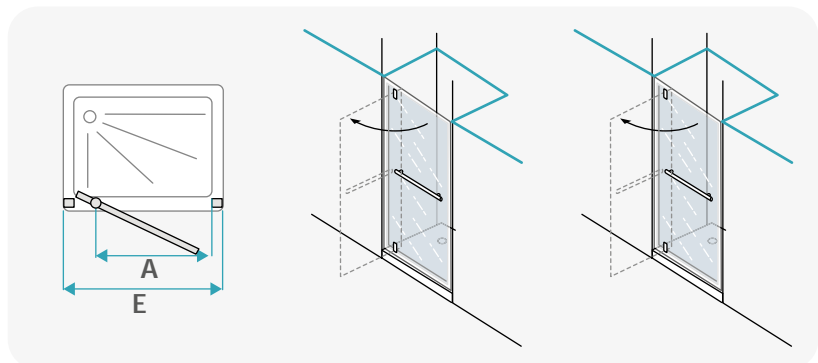
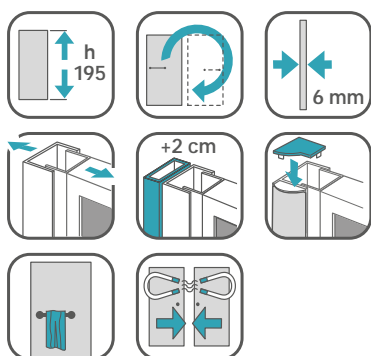

A	E		01		55
cm 50	cm 67-71	CR	B0340PCR01	CR	B0340PCR55
cm 60	cm 77-81	CR	B0342PCR01	CR	B0342PCR55
cm 70	cm 87-91	CR	B0344PCR01	CR	B0344PCR55



Porta battente con elemento fisso / pivot door with fix side / porte tournante avec paroi / flügeltür mit festseite / puera batiente pared fija

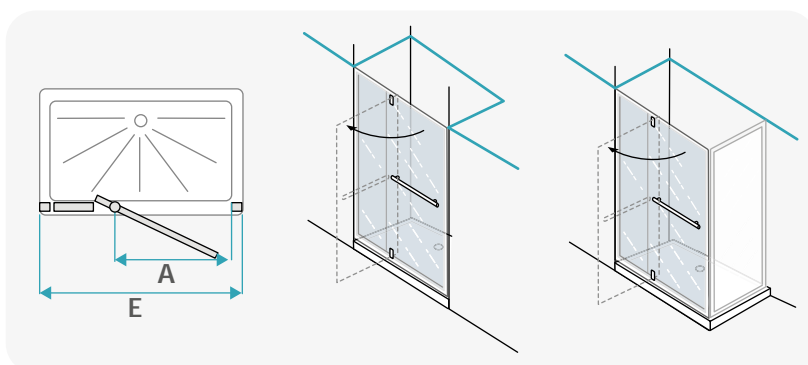
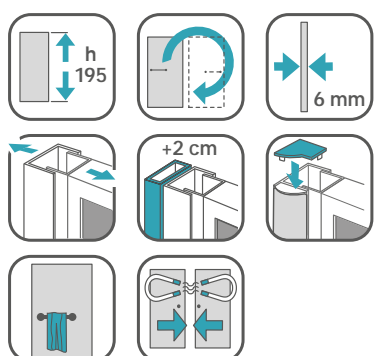

A	E		01		55
cm 69	cm 117-121	CR	B0347PCR01	-	-
cm 69	cm 137-141	CR	B0348PCR01	-	-



Porta a soffietto / folding door / porte a soufflet
falttür / puerta feulle

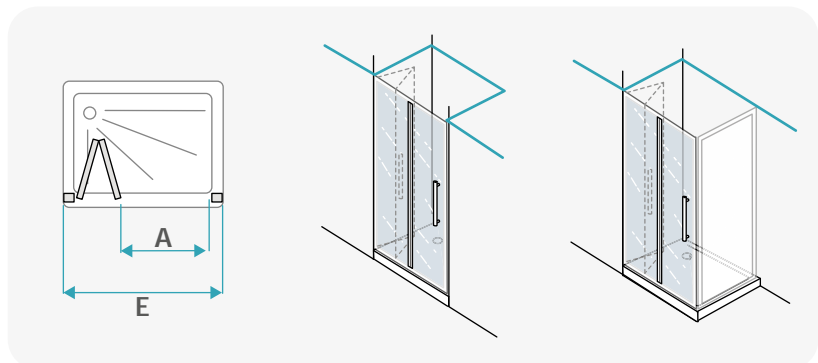
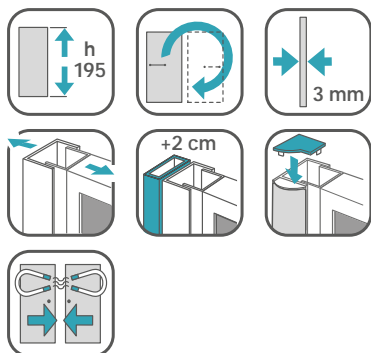

A	E		01		55
cm 52	cm 77-81	CR	B0372PCR01	-	-
cm 62	cm 87-91	CR	B0374PCR01	-	-
cm 72	cm 97-101	CR	B0376PCR01	-	-



Parete fissa / fixed panel / paroi fixe / feste wand / pared fija

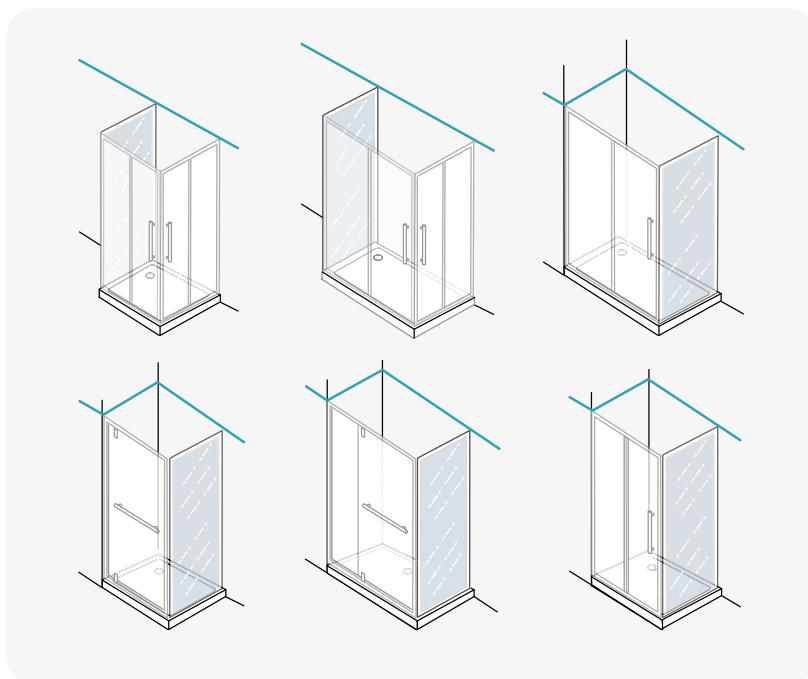
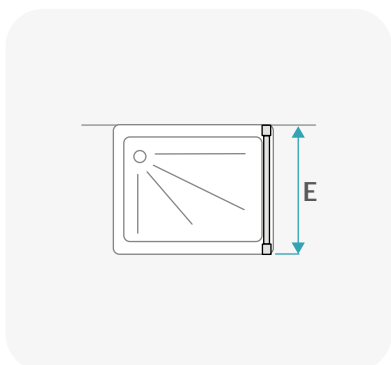
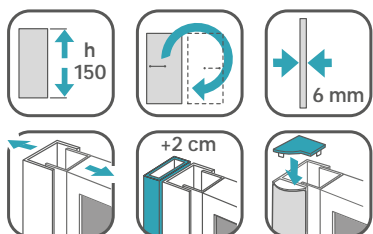

E	T	01		55
cm 67-69	CR	B0350PCR01	CR	B0350PCR55
	WY	B0350PWY01	-	-
cm 77-79	CR	B0352PCR01	CR	B0352PCR55
cm 87-89	CR	B0354PCR01	CR	B0354PCR55



Parete per vasca / bath tub wall / paroi baignoire / badewannewand
pared bañera

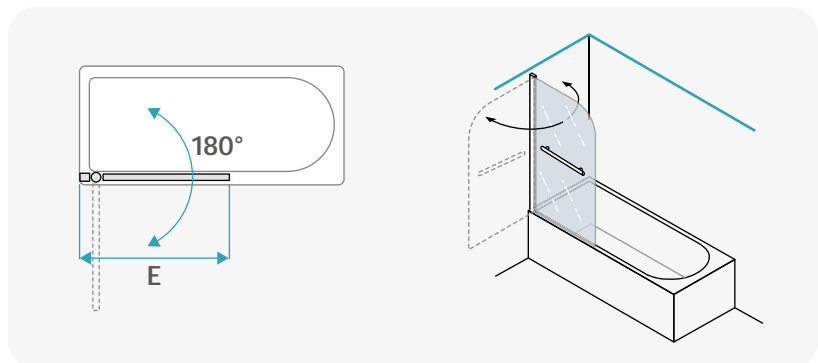
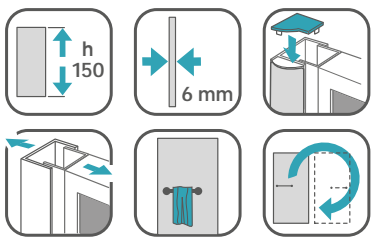

E		 01
cm 90-92	CR	B0385VCR01



Parete per vasca con elemento fisso / bath tub wall fix side / paroi baignoire partie fixe / badewannenwand festseite / pared bañera lado fijo

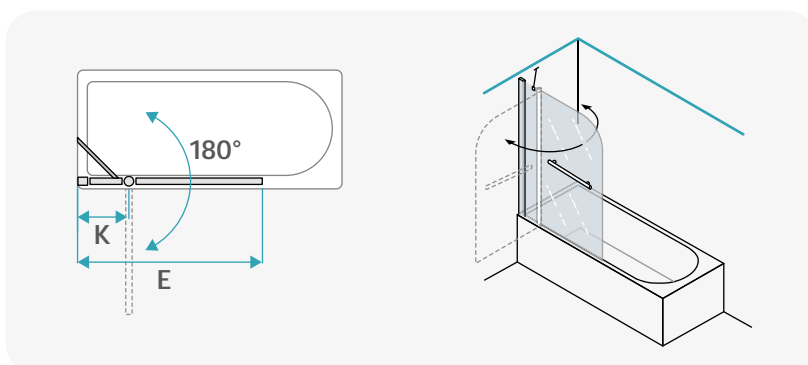
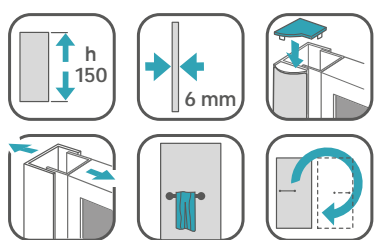

K	E		 01
cm 30	cm 120 - 122	CR	B0387VCR01